

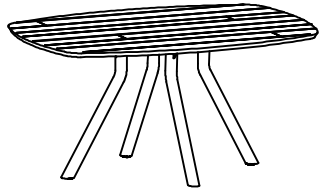

# Assembly instruction

## ARVADA

Option Central equal legs



Oval top

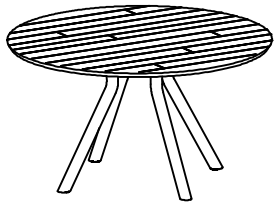

Round top

### Persons needed to assemble

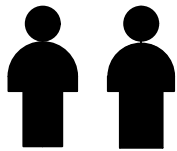

### Time needed to assemble

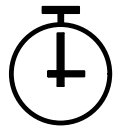

30 min.

#### HARDWARE LIST

ITEM	DESCRIPTION	QTY
A	Bolt M8x20 mm	20
B	L-Key	1

Attention: Hardware is placed in box of the legs!

## Explode view

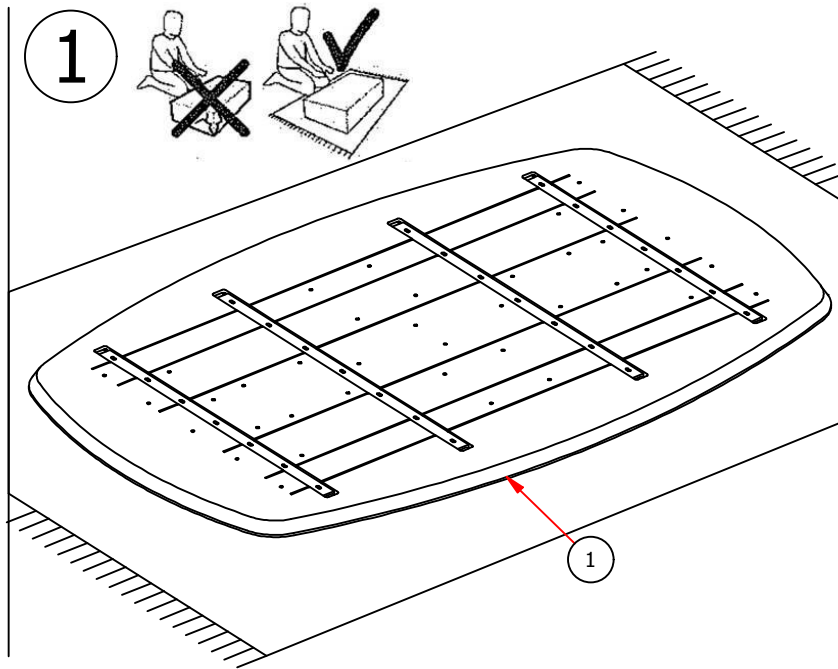
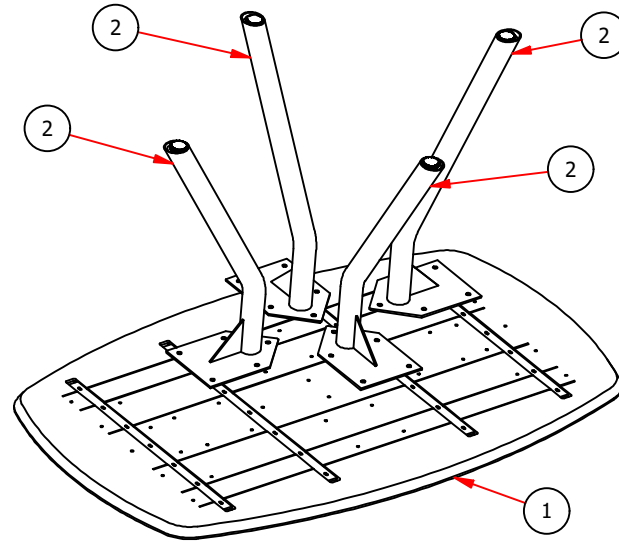

## 2

