

finori GmbH  
Straßäcker 2  
D - 96253 Untersiemau

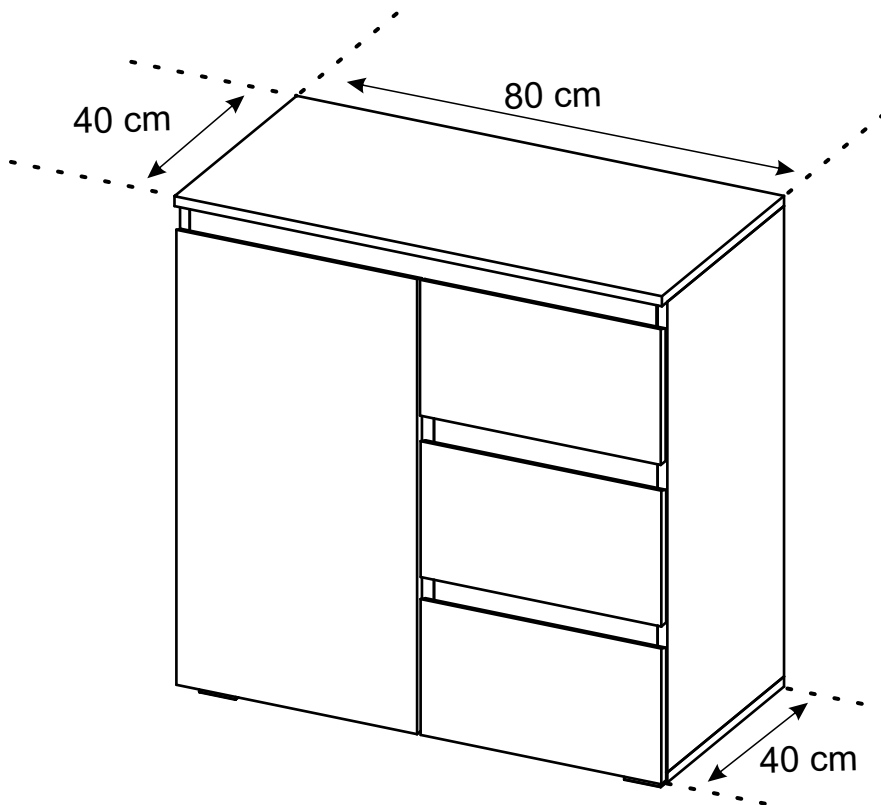

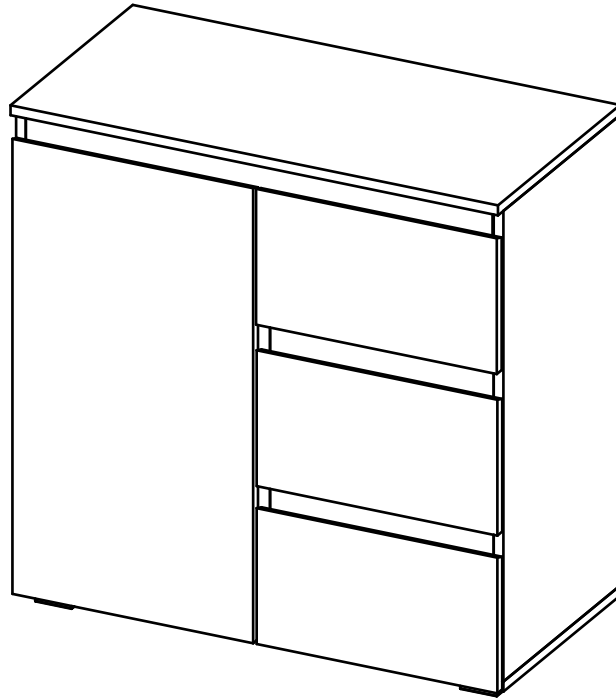
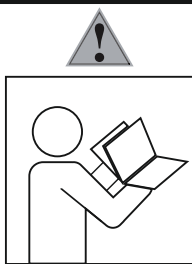

- Ⓓ Befolgen Sie stets die Anleitung des Herstellers!
- ⒸⒷ Please generally follow the manufacturers instructions!
- Ⓕ Suivez toujours les instructions du fabricant!
- Ⓝ Volg steeds de handleiding van de producent!
- Ⓔ Siga siempre las instrucciones del fabricante!
- Ⓟ Stale przestrzegaj instrukcji producenta!

- ⓇⓊ Всегда следуйте инструкции производителя!
- Ⓙ Seguire sempre le istruzioni del produttore!
- ⓇⓊ Mindig tartsa be a gyártó utasításait!
- Ⓟ Siga sempre as instruções do fabricante!
- ⒸⒿ Vždy dodržujte pokyny výrobce!

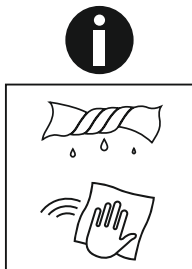

- Ⓓ Verwenden Sie zur Reinigung nur ein feuchtes Tuch!
- ⒸⒷ Please only clean with a damp cloth!
- Ⓕ N'utilisez qu'un chiffon humide pour le nettoyage!
- Ⓝ Gebruik voor de reiniging enkel een vochtige doek!
- Ⓔ Para limpiar utilice sólo un paño húmedo!
- Ⓟ Do czyszczenia używaj wilgotnej szmatki!

- ⓇⓊ Для очистки используйте только влажную ткань!
- Ⓙ Per la pulizia, utilizzare solo un panno umido!
- ⓇⓊ A tisztításhoz elegendő egy nedves kendő használatát!
- Ⓟ Para a limpeza use apenas um pano húmido!
- ⒸⒿ Pro čištění používejte pouze vlhký hadřík!

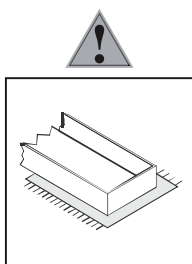

- Ⓓ Bauen Sie das Produkt auf einer Unterlage auf!
- ⒸⒷ Please mount the product on a bottom support!
- Ⓕ Montez le produit sur une base!
- Ⓝ Monteer het product op een basis!
- Ⓔ Monte el producto sobre una base!
- Ⓟ Rozkładaj produkt na podkładce!

- ⓇⓊ Собирайте изделие на подстилке!
- Ⓙ Montare il prodotto su un supporto!
- ⓇⓊ Az összeszereléskor helyezzen a termék alá megfelelő alátétet!
- Ⓟ Monte o produto numa superfície plana!
- ⒸⒿ Výrobek smontujte na pevném podkladu!

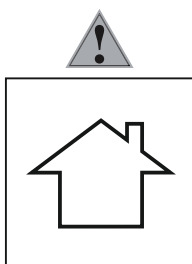

- Ⓓ Verwenden Sie das Produkt nur in Innenräumen!
- ⒸⒷ Please exclusively use the product indoors!
- Ⓕ N'utilisez le produit qu'à l'intérieur!
- Ⓝ Gebruik het product enkel binnenshuis!
- Ⓔ Utilice el producto sólo en interiores!
- Ⓟ Używaj produkt tylko w pomieszczeniach wewnętrznych!

- ⓇⓊ Используйте изделие только во внутренних помещениях!
- Ⓙ Utilizzare il prodotto solo in ambienti interni!
- ⓇⓊ A termék csak bel terekben használható!
- Ⓟ Use o produto apenas no interior!
- ⒸⒿ Používejte výrobek pouze uvnitř!

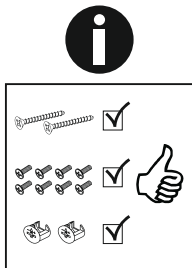

- Ⓓ Legen Sie die Beschläge zusammen und prüfen Sie die Vollständigkeit!
- ⒸⒷ Please join the fittings and verify their completeness!
- Ⓕ Pliez les raccords ensemble et vérifiez qu'ils sont complets!
- Ⓝ Leg de onderdelen samen en controleer de volledigheid!
- Ⓔ Junte los accesorios y compruebe que están todos!
- Ⓟ Rozłóż poszczególne części i sprawdź kompletność!

- ⓇⓊ Положите фурнитуру в одно место и проверьте комплектность!
- Ⓙ Mettere insieme le guarnizioni e verificarne la completezza!
- ⓇⓊ Állítsa össze a sarokvasakat, és ellenőrizze, hogy épek-e!
- Ⓟ Coloque os encaixes juntos e verifique se estão completos!
- ⒸⒿ Složte armatury a zkontrolujte úplnost!

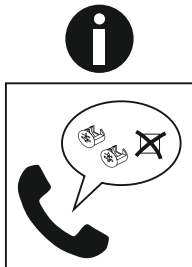

- Ⓓ Bei fehlenden Teilen kontaktieren Sie den Hersteller!
- ⒸⒷ If parts are missing, please turn to the manufacturer!
- Ⓕ En cas de pièces manquantes, veuillez contacter le fabricant!
- Ⓝ Contacteer de fabrikant als er onderdelen ontbreken!
- Ⓔ En el caso de que falten piezas, póngase en contacto con el fabricante!
- Ⓟ W razie braku części skontaktuj się z producentem!

- ⓇⓊ При отсутствии каких-либо частей обратитесь к производителю!
- Ⓙ In caso di pezzi mancanti, contattare il produttore!
- ⓇⓊ Ha hiányozna valamelyik elem, lépjen kapcsolatba a gyártóval!
- Ⓟ Em caso de peças em falta, entre em contato com o fabricante!
- ⒸⒿ Pro chybějící díly kontaktujte výrobce!

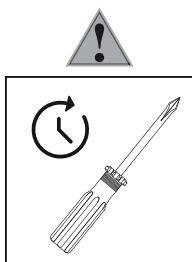

- Ⓓ Ziehen Sie die Schrauben nach einiger Zeit des Gebrauchs erneut fest!
- ⒸⒷ Please re-tighten the screws after having used the product for a while!
- Ⓕ Resserrer les vis après un certain temps d'utilisation!
- Ⓝ Draai de schroeven na een zekere gebruikstijd opnieuw vast!
- Ⓔ Asegure de nuevo los tornillos tras usarlo durante un tiempo!
- Ⓟ Po pewnym czasie użytkowania ponownie dokręć śruby!

- ⓇⓊ Спустя некоторое время использования подкрутите гайки!
- Ⓙ Stringere nuovamente le viti dopo un certo periodo di utilizzo!
- ⓇⓊ A használat során némi idő elteltével húzza meg újra a csavarokat!
- Ⓟ Reaperte os parafusos após algum tempo de uso!
- ⒸⒿ Po určité době používání rouby znovu utáhněte!

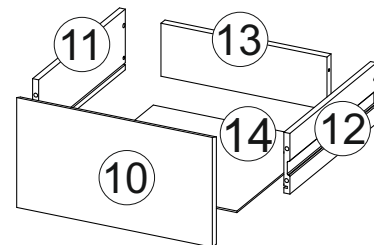
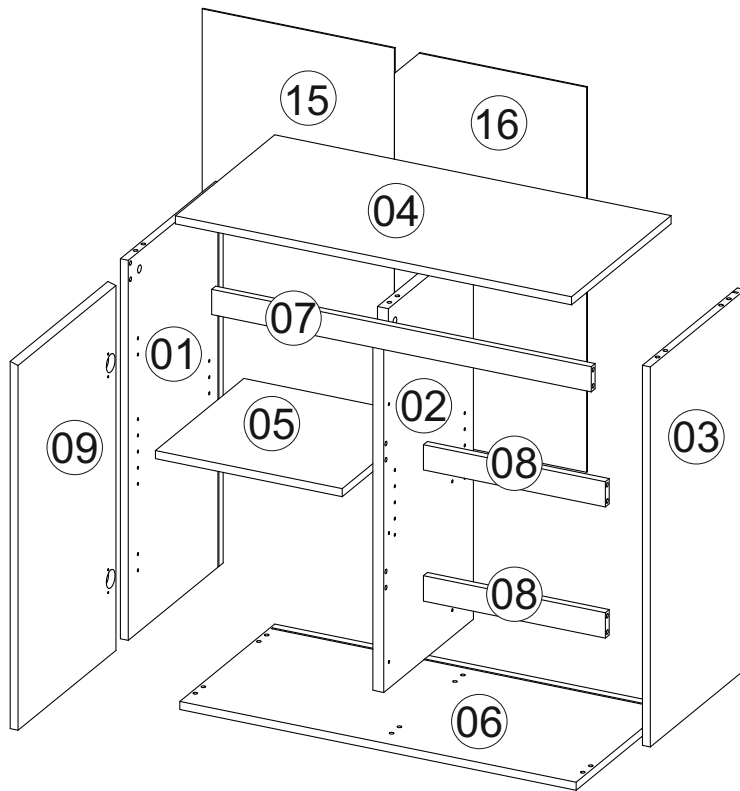
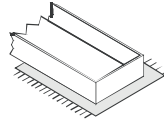
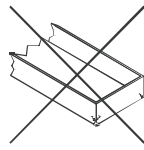
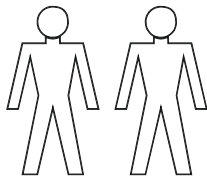
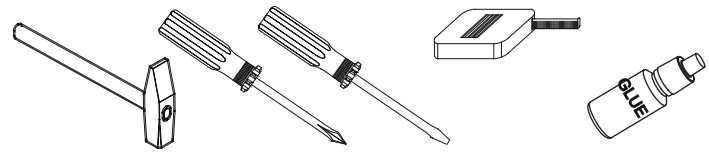

x3

**BOX 1**

1x01; 1x02; 1x03; 1x04; 1x05; 1x06; 1x07; 2x08; 1x09; 3x10; 3x11; 3x12; 3x13; 3x14; 1x15; 1x16;

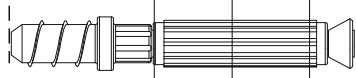
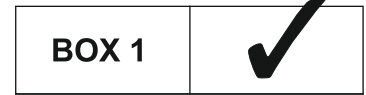
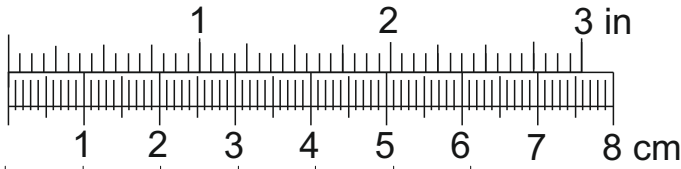

Cx6



Ax24

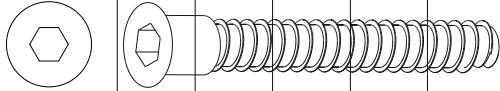

Ex12



Fx6

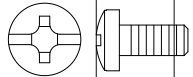

lx6

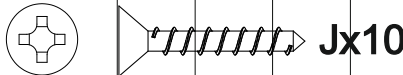

Jx10

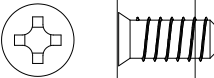

Kx12

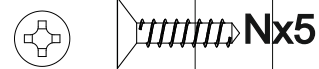

Nx5

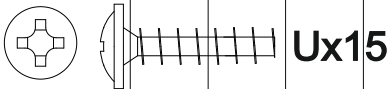

Ux15

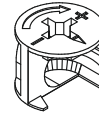

Bx6



Dx4

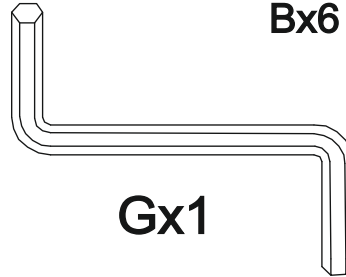

Gx1

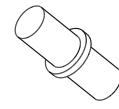

Hx4



Lx2

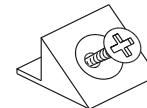

Mx8

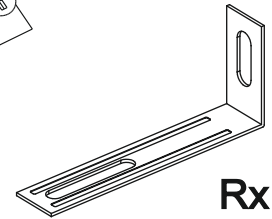

Rx1

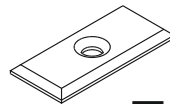

Tx6

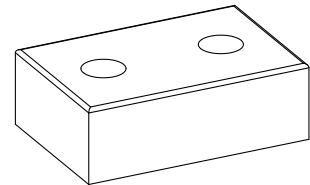

Sx5

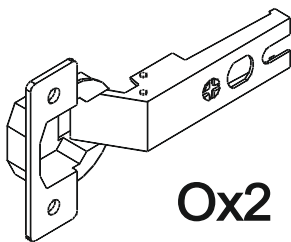

Ox2

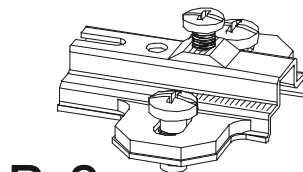

Px2

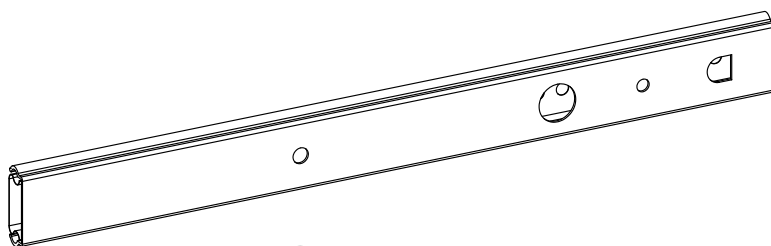

Qx6

## A

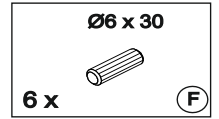
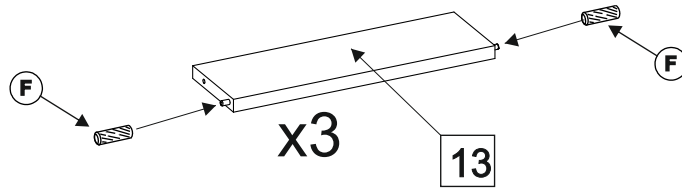

## B

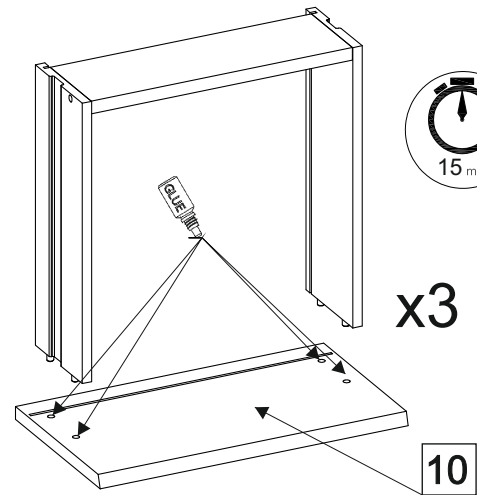
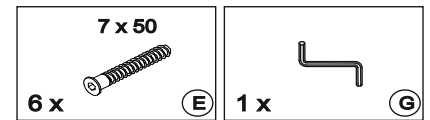
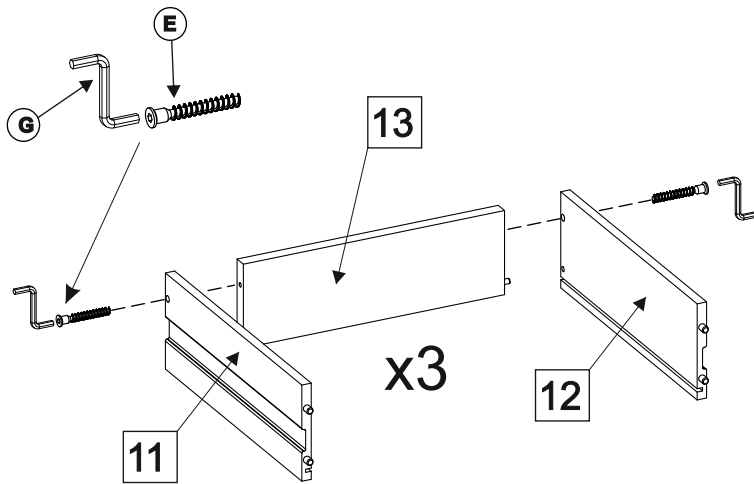

## C

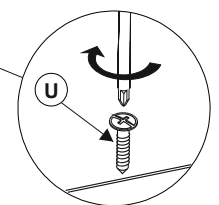
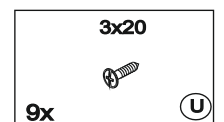
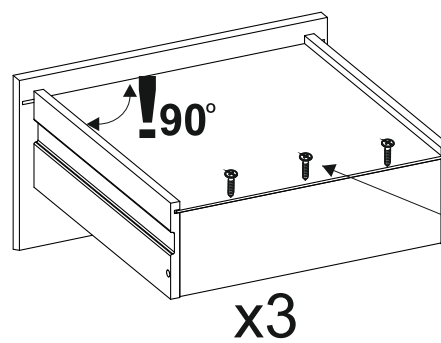
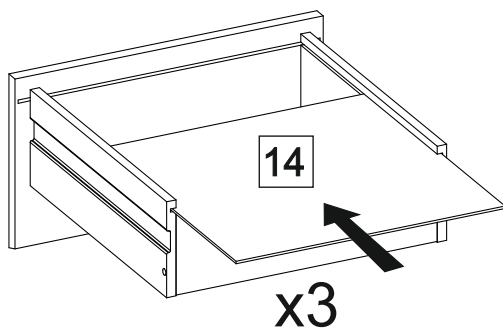

D

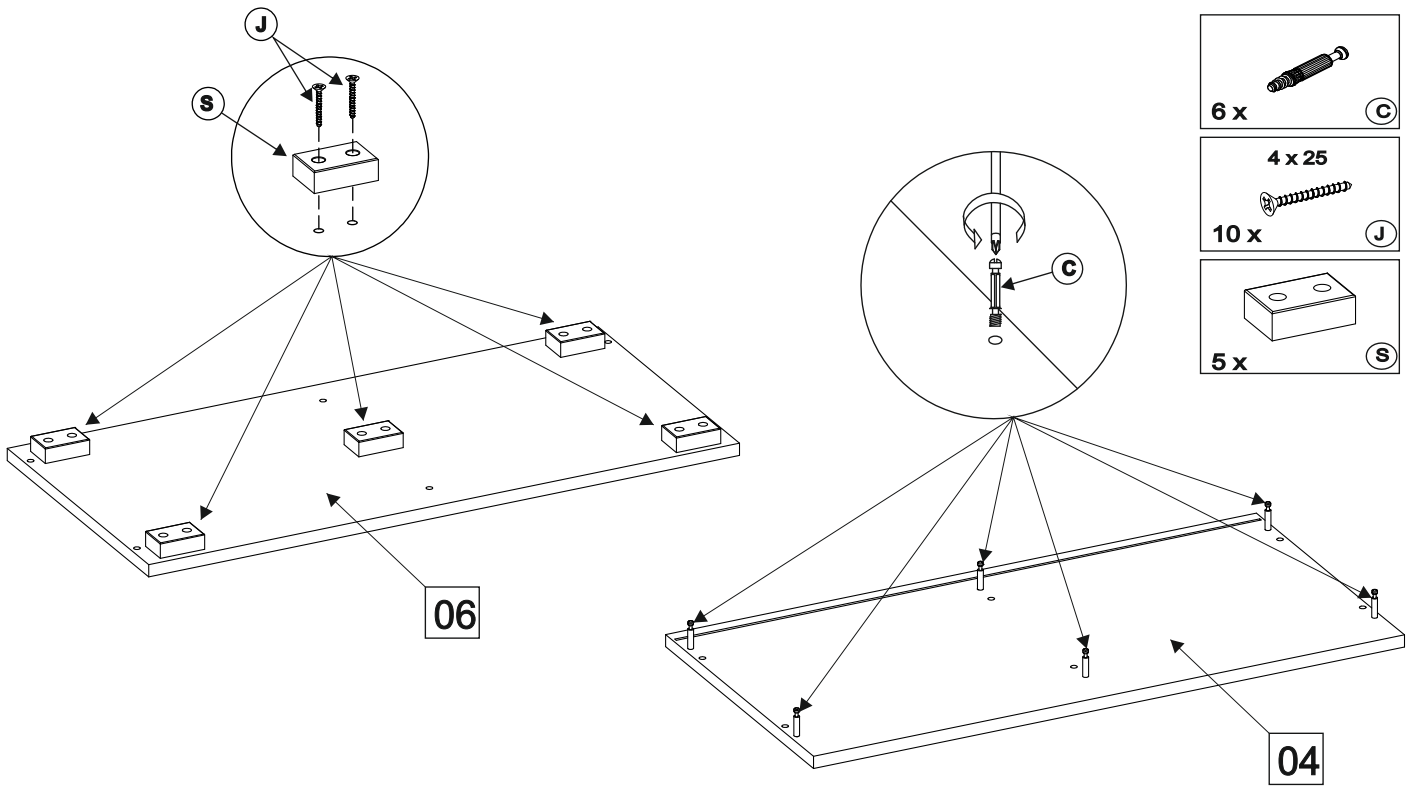

E

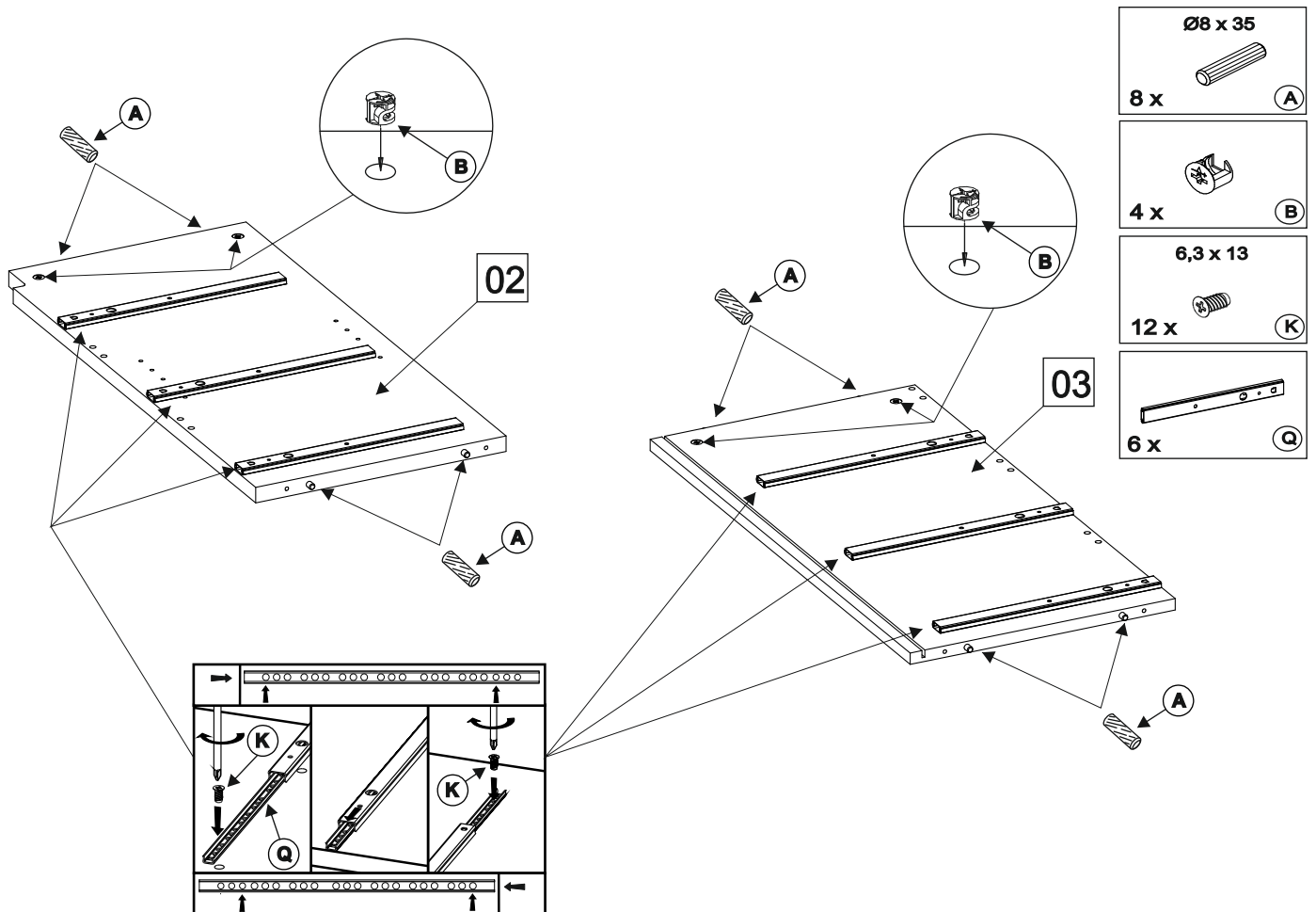

F

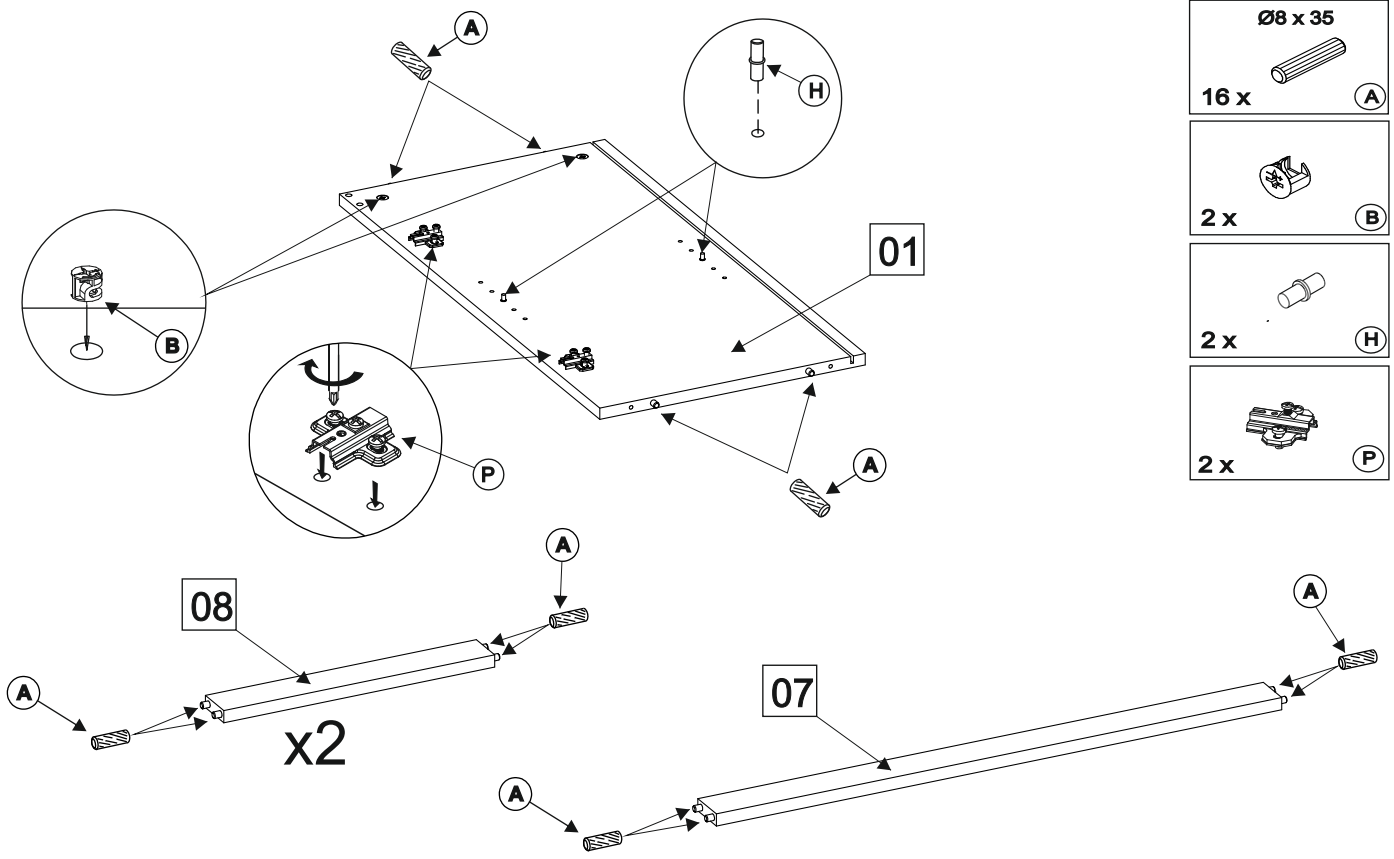

G

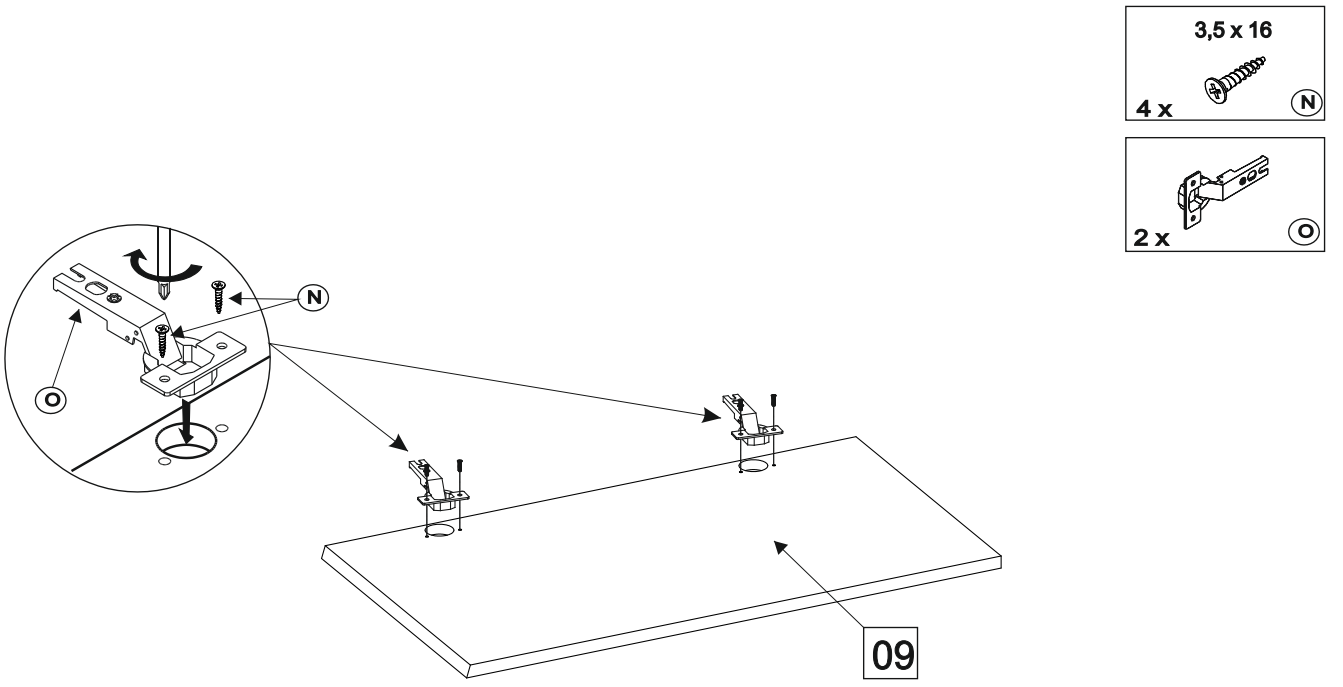

H

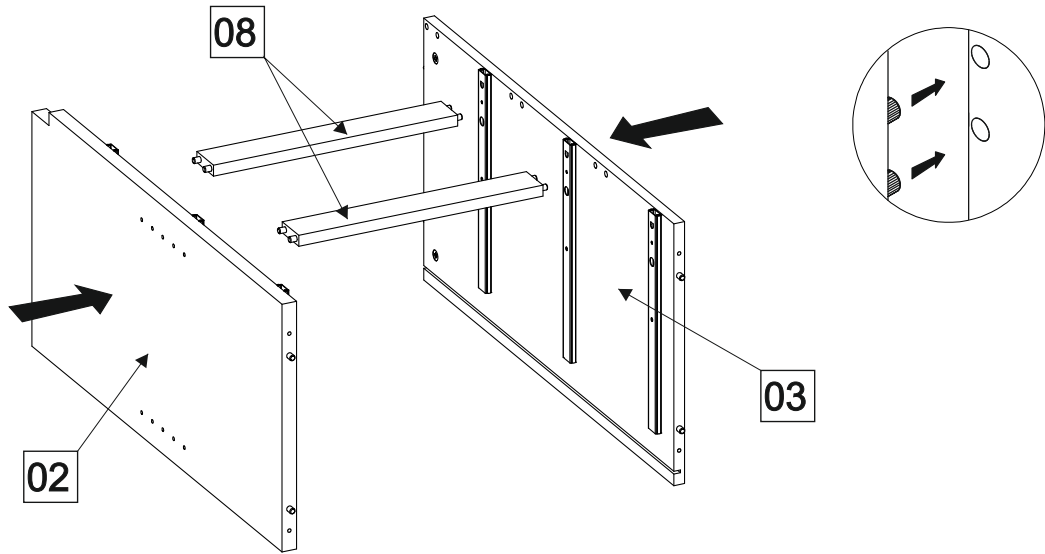

I

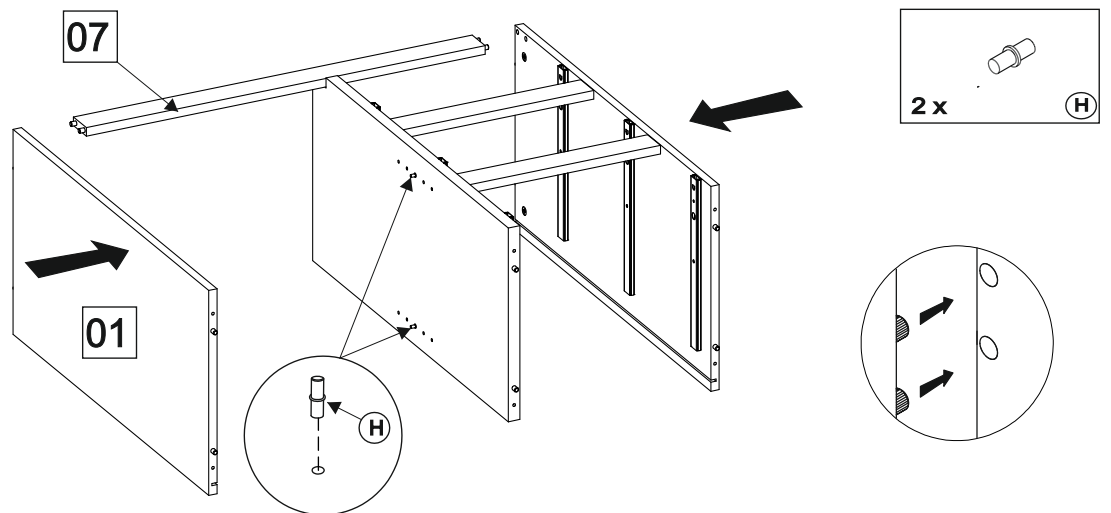

J

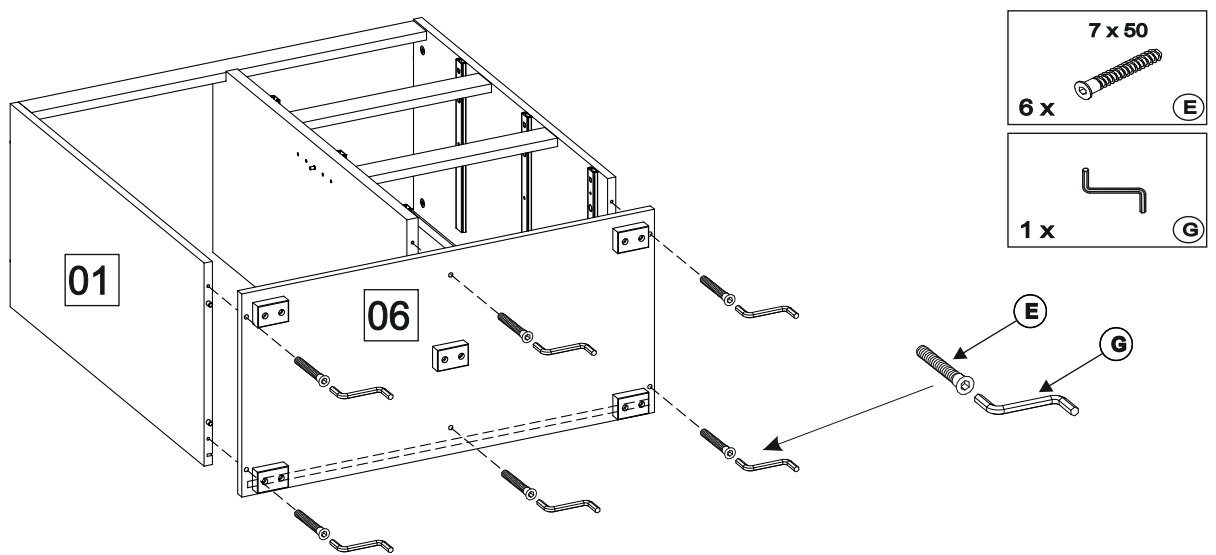



K

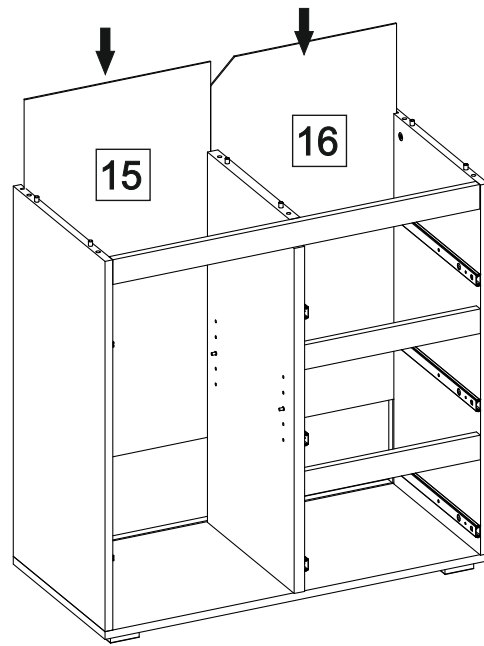

L

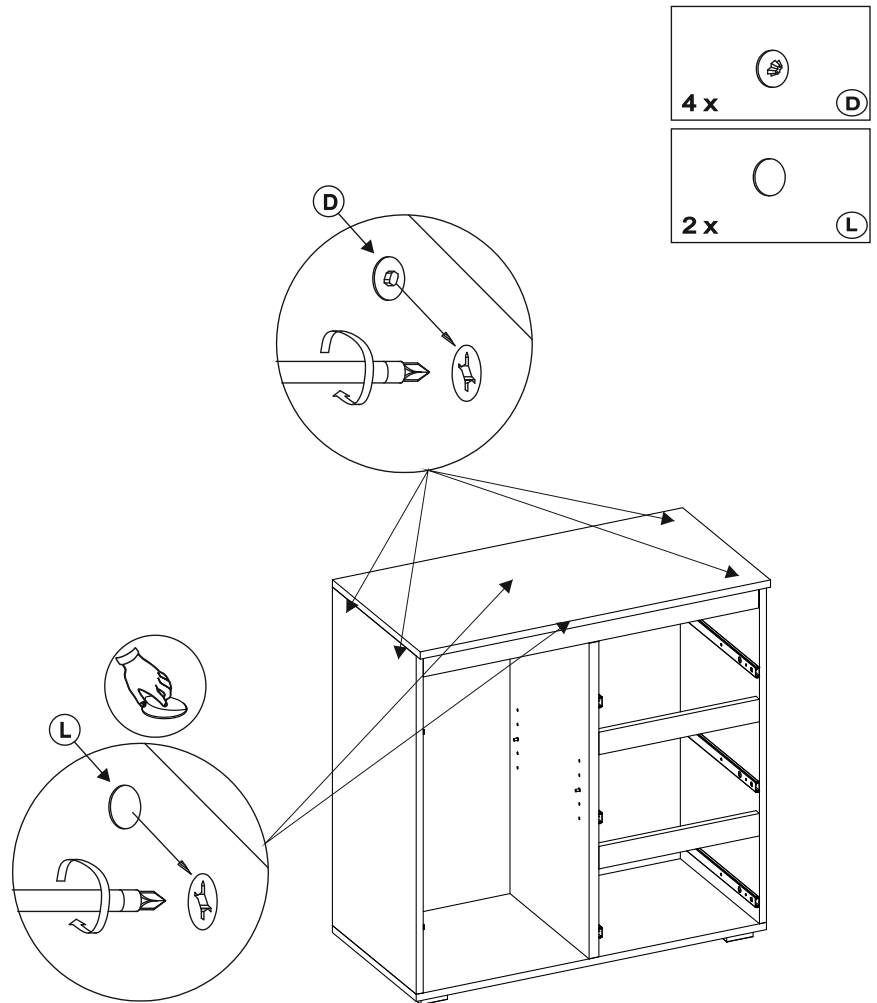
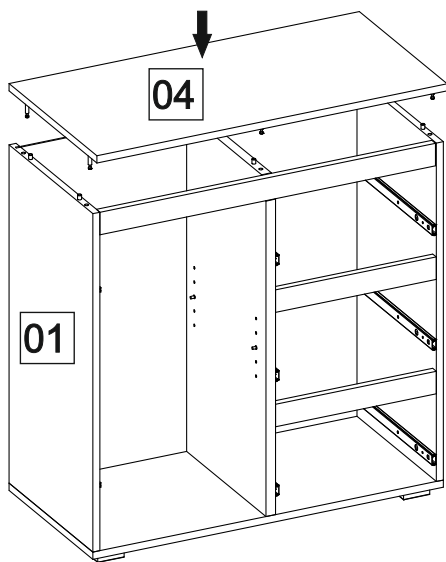

M

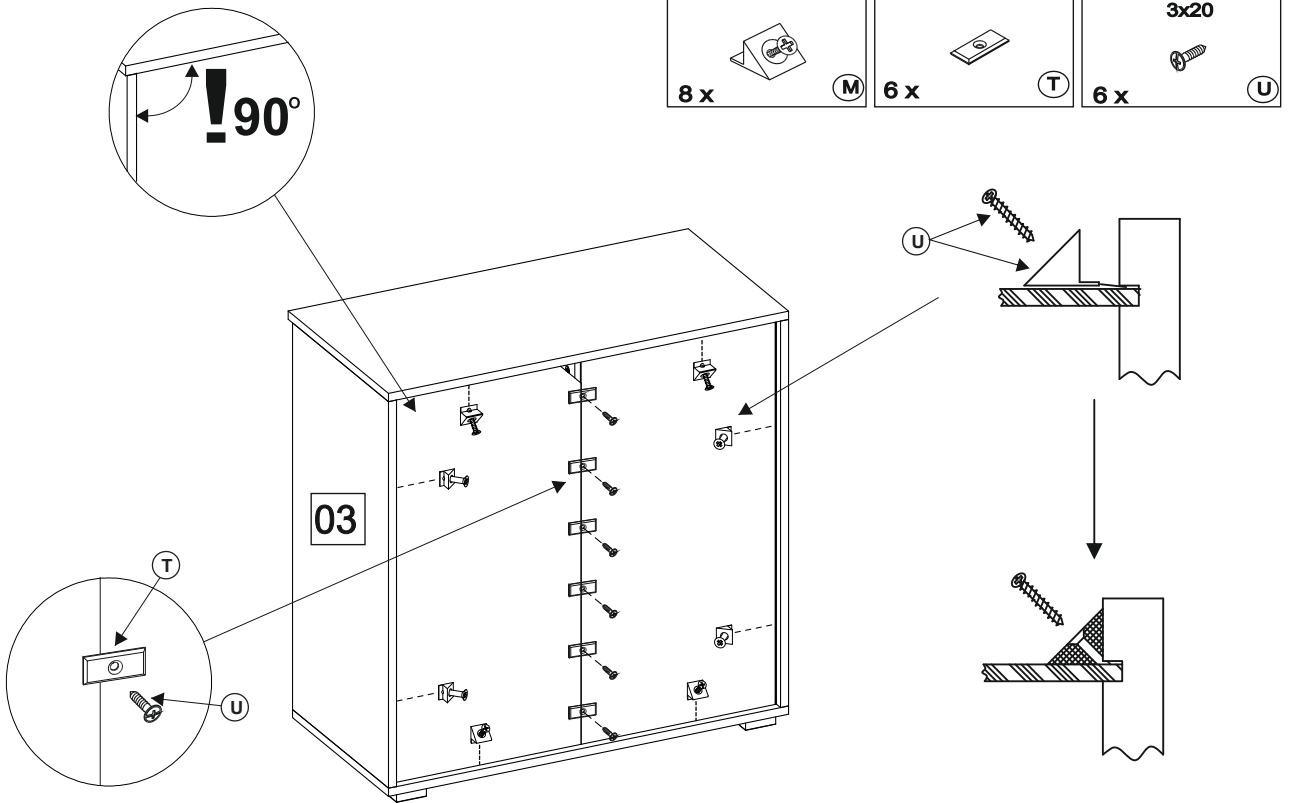

N

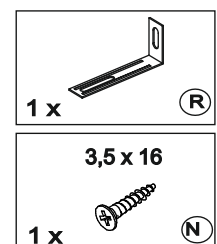
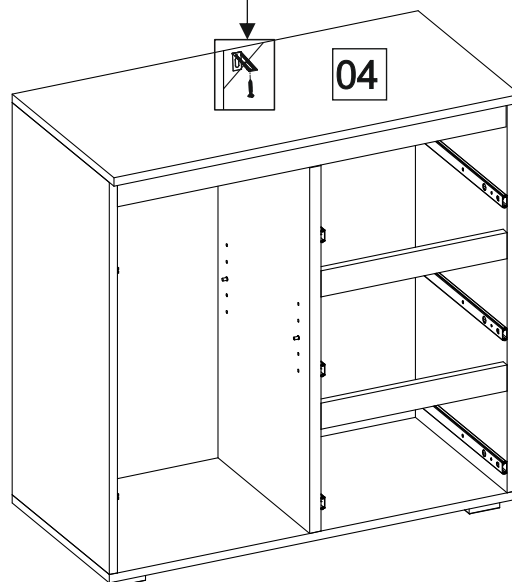
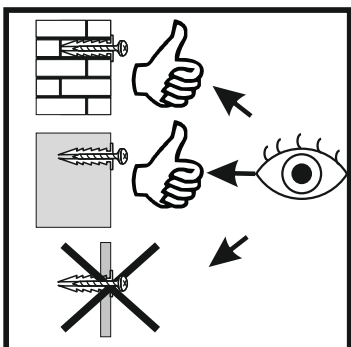
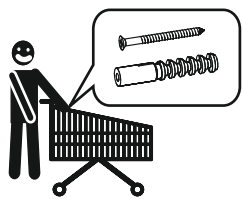
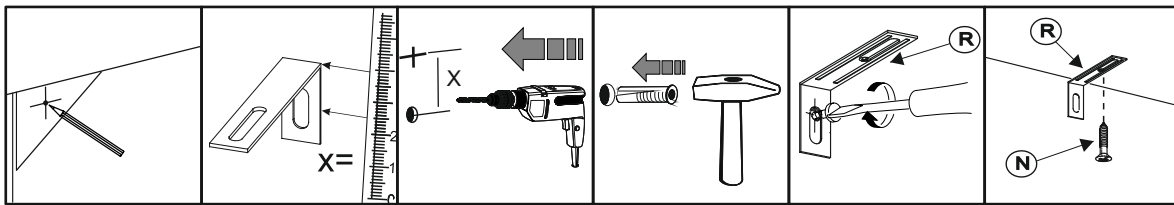

O

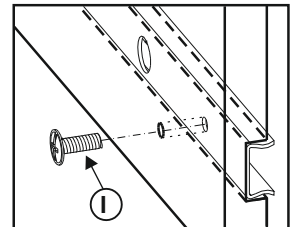
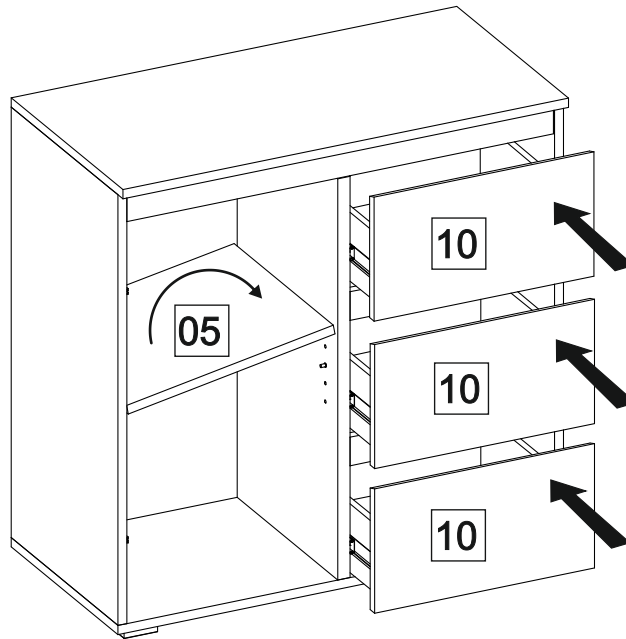
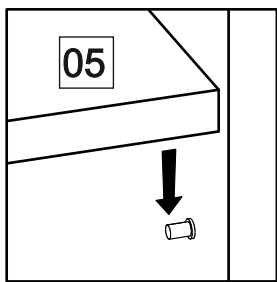
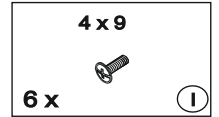

P

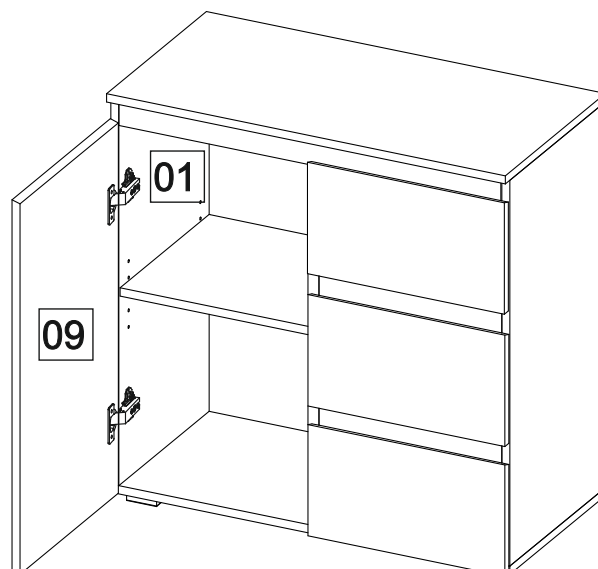
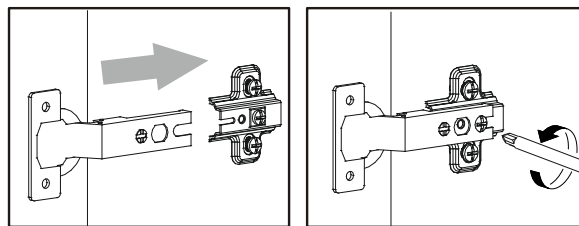

Q

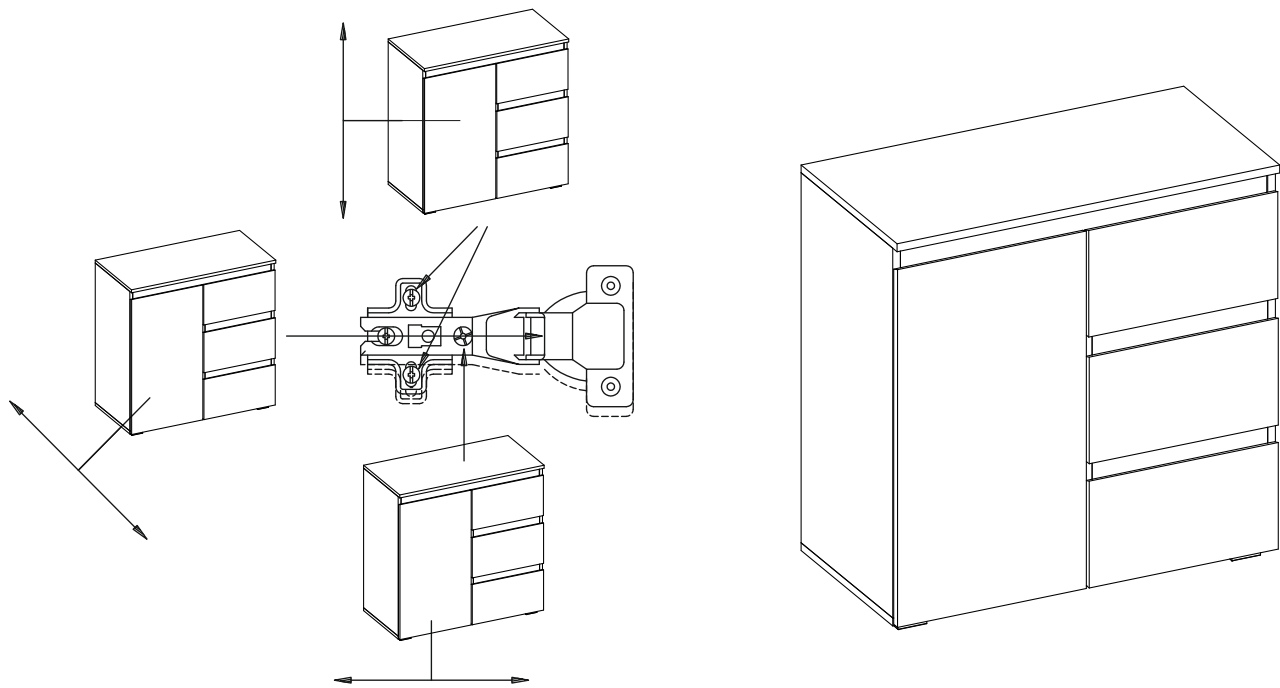



- (D) Das Möbel muss an der Wand befestigt werden!
- (GB) Please ensure to mount the furniture to the wall!
- (FR) Les meubles doivent être fixés au mur!
- (NL) Het meubel moet aan de wand worden vastgemaakt!
- (ES) El mueble se tiene que fijar a la pared!
- (PL) Mebel należy przymocować do ściany!

- (RU) Мебель должна крепиться к стене!
- (IT) Il mobile deve essere fissato alla parete!
- (HU) A bútor a falon rögzítendő!
- (P) O móvel tem que ser fixado na parede!
- (CZ) Nábytek musí být připevněn ke stěně!



- (D) Informieren Sie sich vor der Wandmontage über das geeignete Montagematerial!
- (GB) Please get informed on suitable assembly materials before commencing the wall-mounting!
- (FR) Renseignez-vous sur le matériel de montage approprié avant le montage mural!
- (NL) Informeer u voor de wandmontage over het geschikte montagematerieel!
- (ES) Infórmese antes del montaje en la pared del material apropiado de montaje!
- (PL) Przed montażem na ścianie upewnij się, jaki jest potrzebny właściwy materiał montażowy!

- (RU) Перед тем, как крепить мебель к стене, получите информацию о подходящем крепежном материале!
- (IT) Prima del fissaggio alla parete, informarsi sul materiale di montaggio adatto!
- (HU) A falra szerelés előtt tájékozódjon, hogy ehhez milyen szerelőanyagok szükségesek!
- (P) Antes da montagem na parede, informe-se sobre o material de montagem adequado!
- (CZ) Informujte se o vhodném montážním materiálu před montáží na stěnu!



- (D) Beschaffen Sie sich das angemessene Material zur Wandbefestigung!
- (GB) Please obtain suitable wall-mounting materials!
- (FR) Procurez-vous le matériel approprié pour le montage mural!
- (NL) Verschaf u het adequate materieel voor de wandbevestiging!
- (ES) Procúrese el material adecuado para la fijación a la pared!
- (PL) Zakup odpowiedni materiał do przymocowania na ścianie!

- (RU) Приобретите соответствующий материал для крепления к стене!
- (IT) Procurarsi il materiale opportuno per il fissaggio alla parete!
- (HU) Szerezze be a falra szereléshez szükséges, megfelelő anyagokat!
- (P) Obtenha o material adequado para a montagem na parede!
- (CZ) Opatřte si vhodný materiál pro montáž na stěnu!



- (D) Lassen Sie die Wandbefestigung von einer fachkundigen Person vornehmen!
- (GB) Ensure all wall-mounting is carried out by competent personnel!
- (FR) Faites effectuer le montage mural par une personne compétente!
- (NL) Laat de wandbevestiging door een professional uitvoeren!
- (ES) Deje que la fijación a la pared la haga un profesional!
- (PL) Zleć przymocowanie do ściany odpowiednio doświadczonej osobie!

- (RU) Поручите выполнение работ по креплению к стене специалисту!
- (IT) Far effettuare il fissaggio alla parete ad un esperto!
- (HU) A bútor falra rögzítését végeztesse ehhez értő személlyel!
- (P) A montagem na parede deve ser executada por uma pessoa competente!
- (CZ) Montáž na stěnu nechte provést odborně způsobilou osobou!

