



W	3W
GU10	GU10
Im	230 Lumen
t	30.000h
T _k	3.000 Kelvin
15.000 x	15.000 x
<0.5 S	<0.5 S

991651



230V / 50Hz 1x GU10 max. 3W

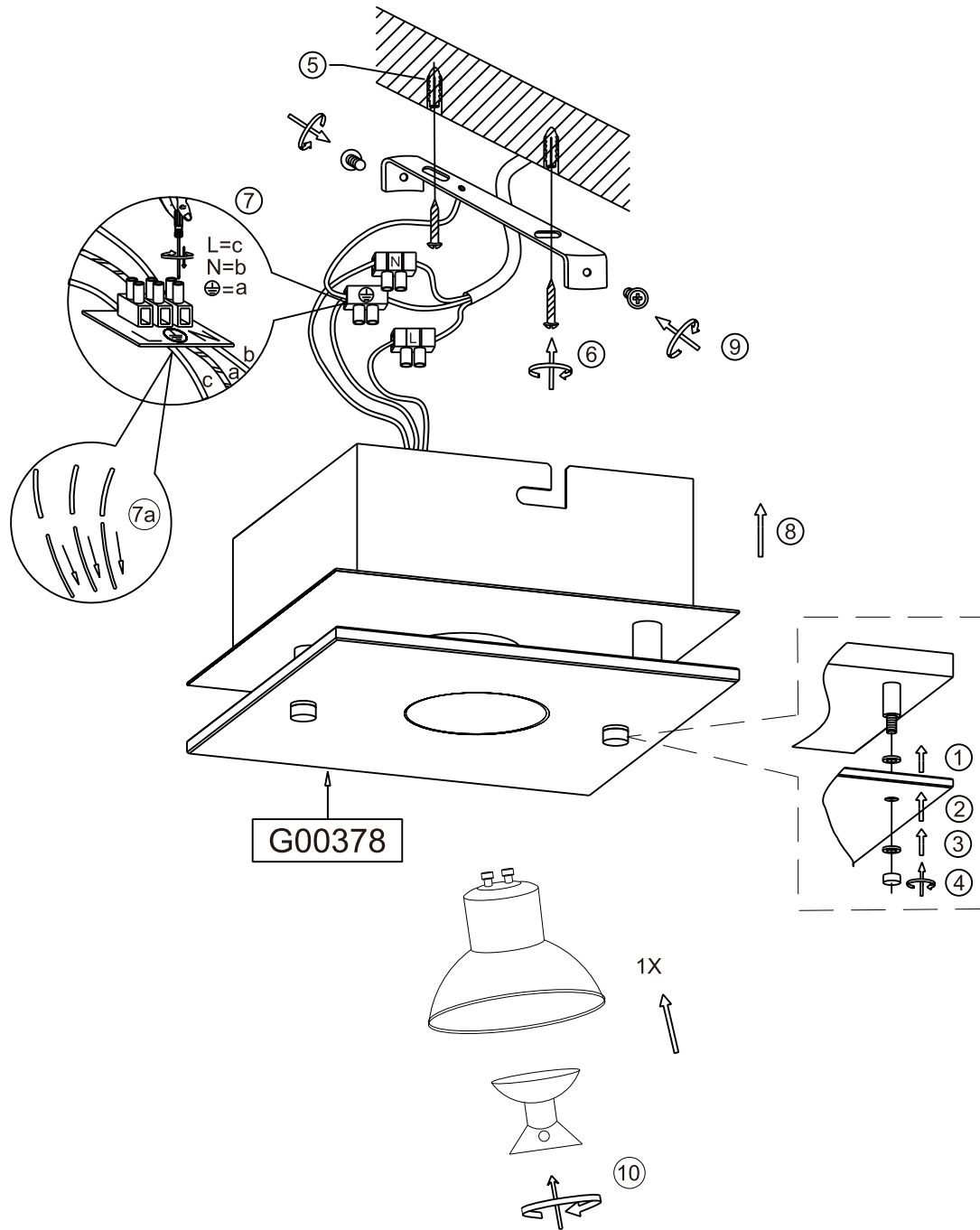

Bitte geben Sie bei technischen Fragen die Chargennummer (xxxxx-xx-xx-xxxxx-xxxx) an. Diese finden Sie auf dem Typenschild.

Please let us know the batch number (xxxxx-xx-xx-xxxxx-xxxx) for any technical questions. This can be found on the rating label.

Lors de demande d'assistance technique, veuillez indiquer le numéro du lot (xxxxx-xx-xx-xxxxx-xxxx). Celui-ci se trouve sur la plaque d'identification.

06/2017