

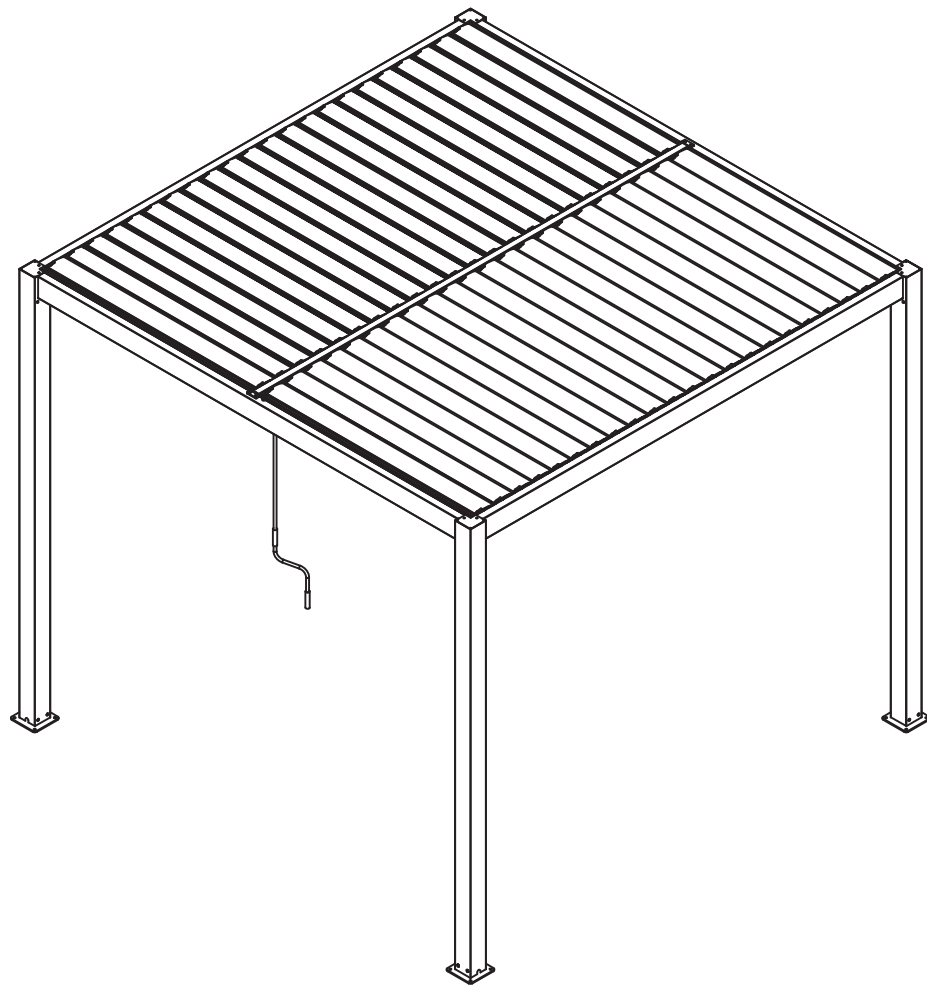





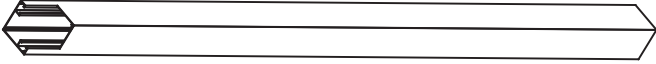

# Manual Instruction

## Pergola



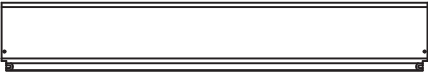
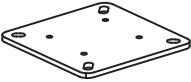
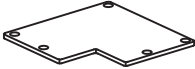
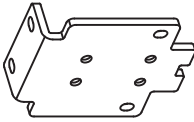

3×3M, 3×4M, 4×3M, 4×4M

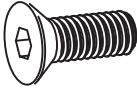
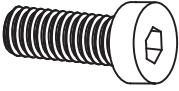
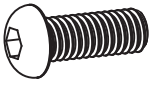

# Spare parts list

Label No.	Part description	Drawing	Qty
A	Column		4
B1	Beam (Left)		1
B2	Beam (Right)		1
C	Front and Rear beams		2
D	Middle Beam		1
E	Slat or Louver		3*3=44 4*3=44 3*4=60 4*4=60
F	Column Bottom Plate		4
G	Column Cover Plate		4
H	Connectors for Middle Beam		2
I	Coner nut		8
J	Holddown 1		8
L	Hinge ring		2
M	Hand Crank		1

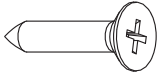
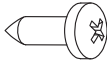
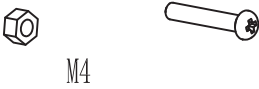
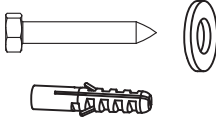
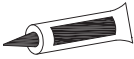
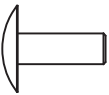
# Spare parts list

Label No.	Part description	Drawing	Qty
K1	Inner hexagonal screw	 M6x16	8
K2	Hexagon socket head screws	 M8*25	16
K3	Hexagon Pan head screws	 M6x16	16
K4	Flat washer	 $\phi 6$	8
K5	Cross recessed countersunk head tapping screws	 ST5.5*32	16
K6	Cross recessed pan head tapping screws	 ST5.5*16	12
K7	Screw+nut	 M4 M4x20	2
K8	Woodworking screw+ plastic expansion pipe + Flat washer	 M8x75 $\phi 8$ $\phi 10 \times 50$	16
K9	Glass Glue		1
N	Plastic jam		3*3=88 4*3=88 3*4=120 4*4=120
O	Hole jam		16
P	Nut cover		16

1. Install the bottom plate F on the column A, and tighten the screw K5.

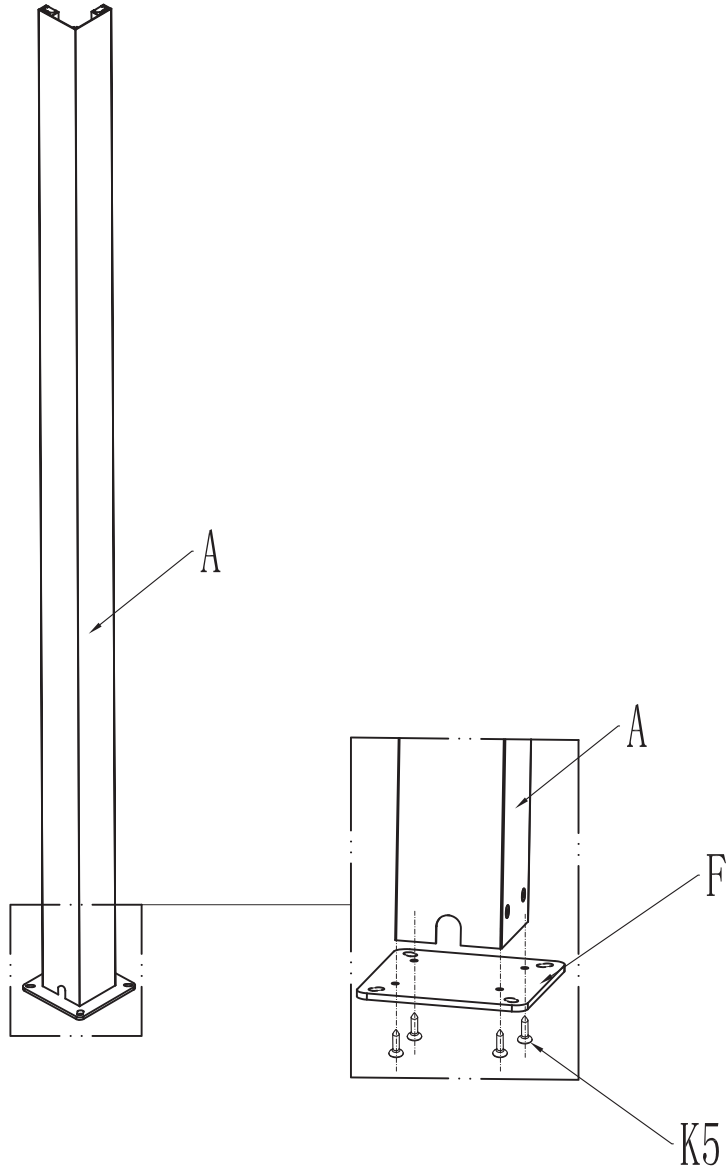

K5

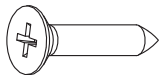

QTY: 16PCS

F



QTY: 4PCS

2. Match the connector H with one side of middle beam D, then tighten the screw K1; then complete the other side.

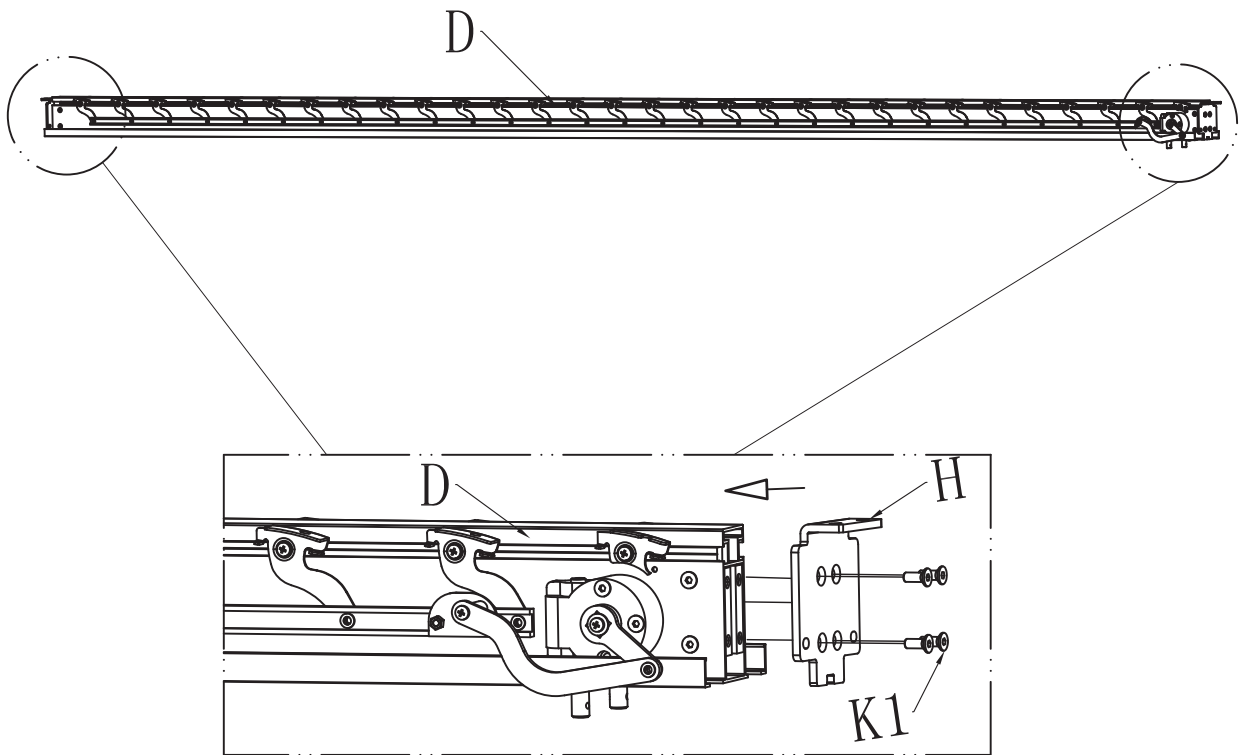

K1



QTY: 8PCS

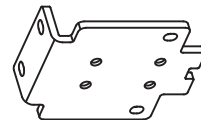

H



QTY: 2PCS

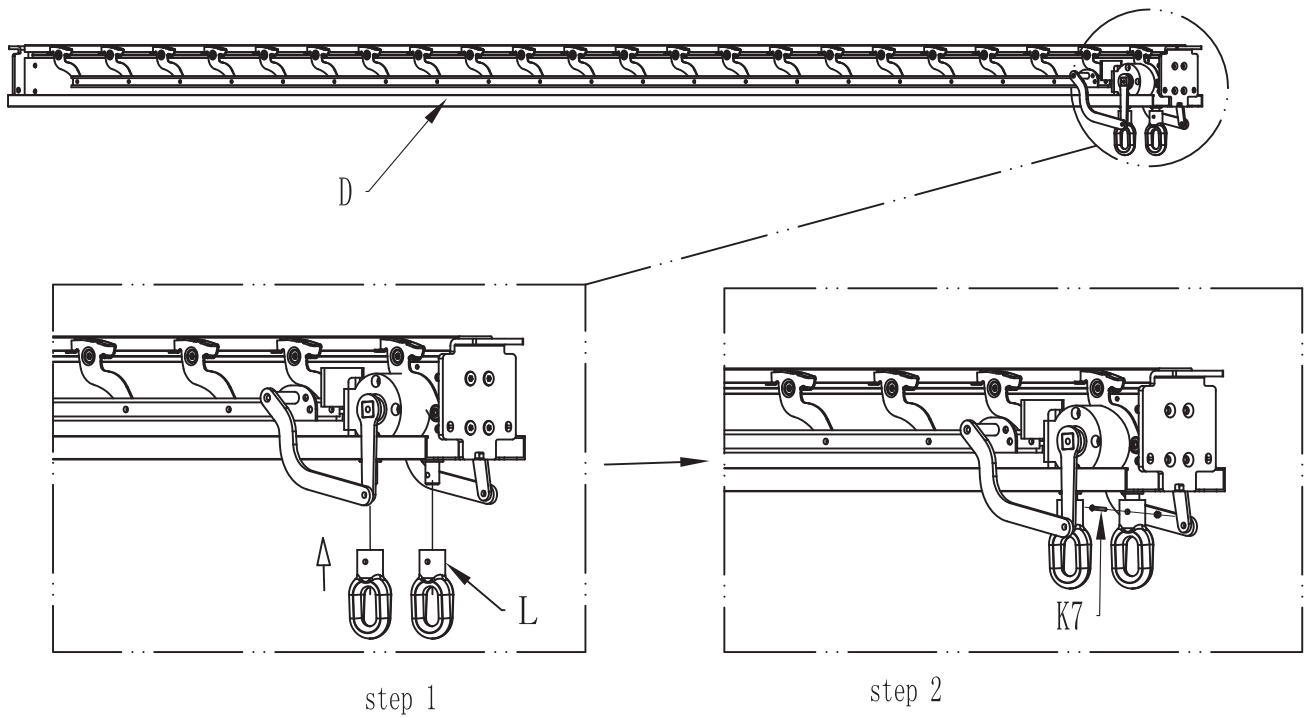

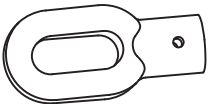
3. Put two hinge rings L into the gearbox drive shaft on the beam D, fix the screw + nut K4.

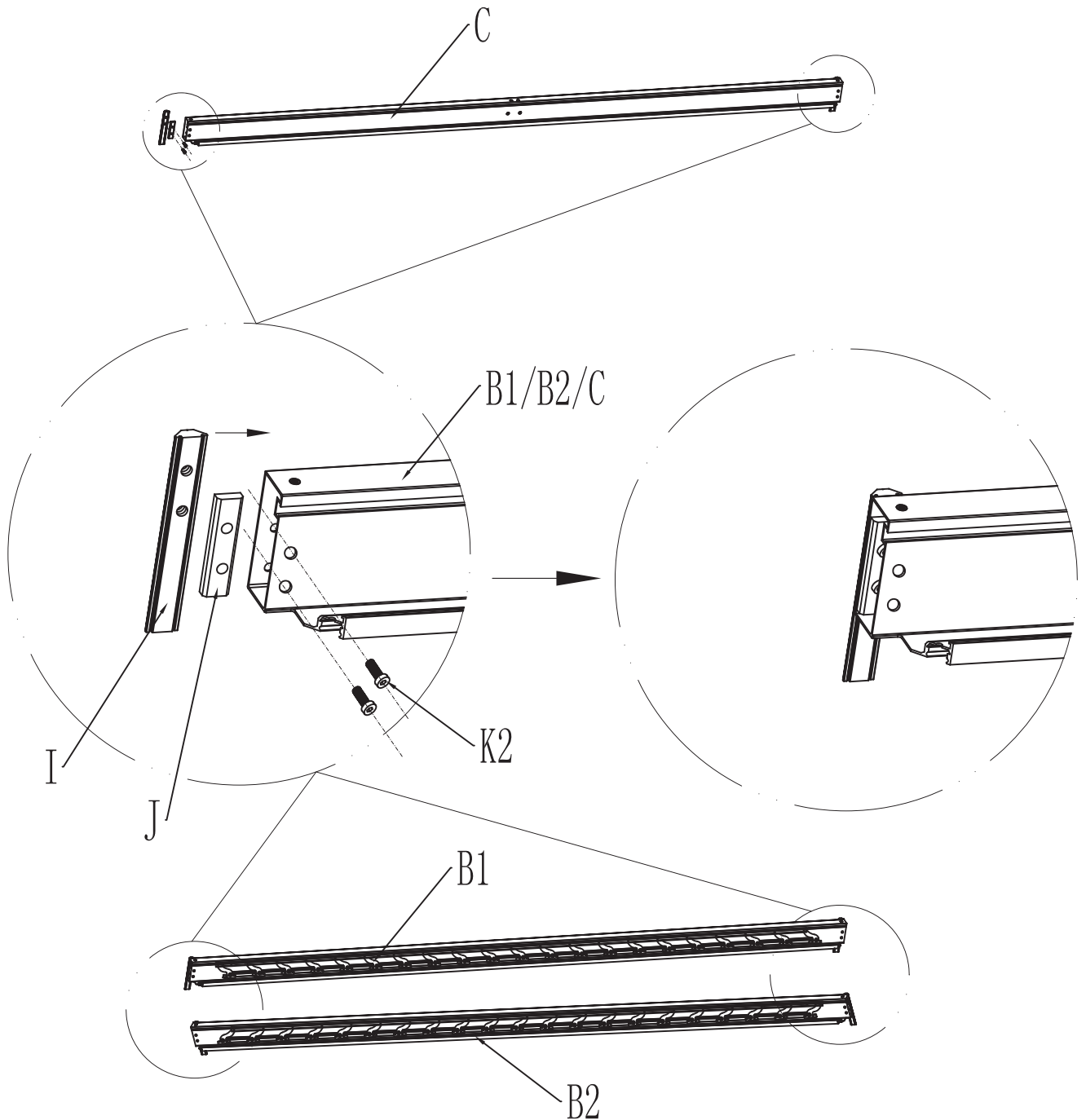

L		QTY: 2PCS	K7	M4 		M4*20	QTY: 2SET
---	-------------------------------------------------------------------------------------	-----------	----	----------------------------------------------------------------------------------------	--------------------------------------------------------------------------------------	-------	-----------

4. Place the pressure block I (J) into the beam B1/B2/C, and place the corner nut strip (I) outside the beam B1/B2/C. Align the corresponding holes and connect the pressure block I (J) corner nut strip (I) with the beam B1/B2/C using K2 screws. Do not tighten the K2 screws (3-5mm empty); Complete the other end again.



I  QTY: 8PCS	J  QTY: 8PCS
K2  QTY: 16PCS	

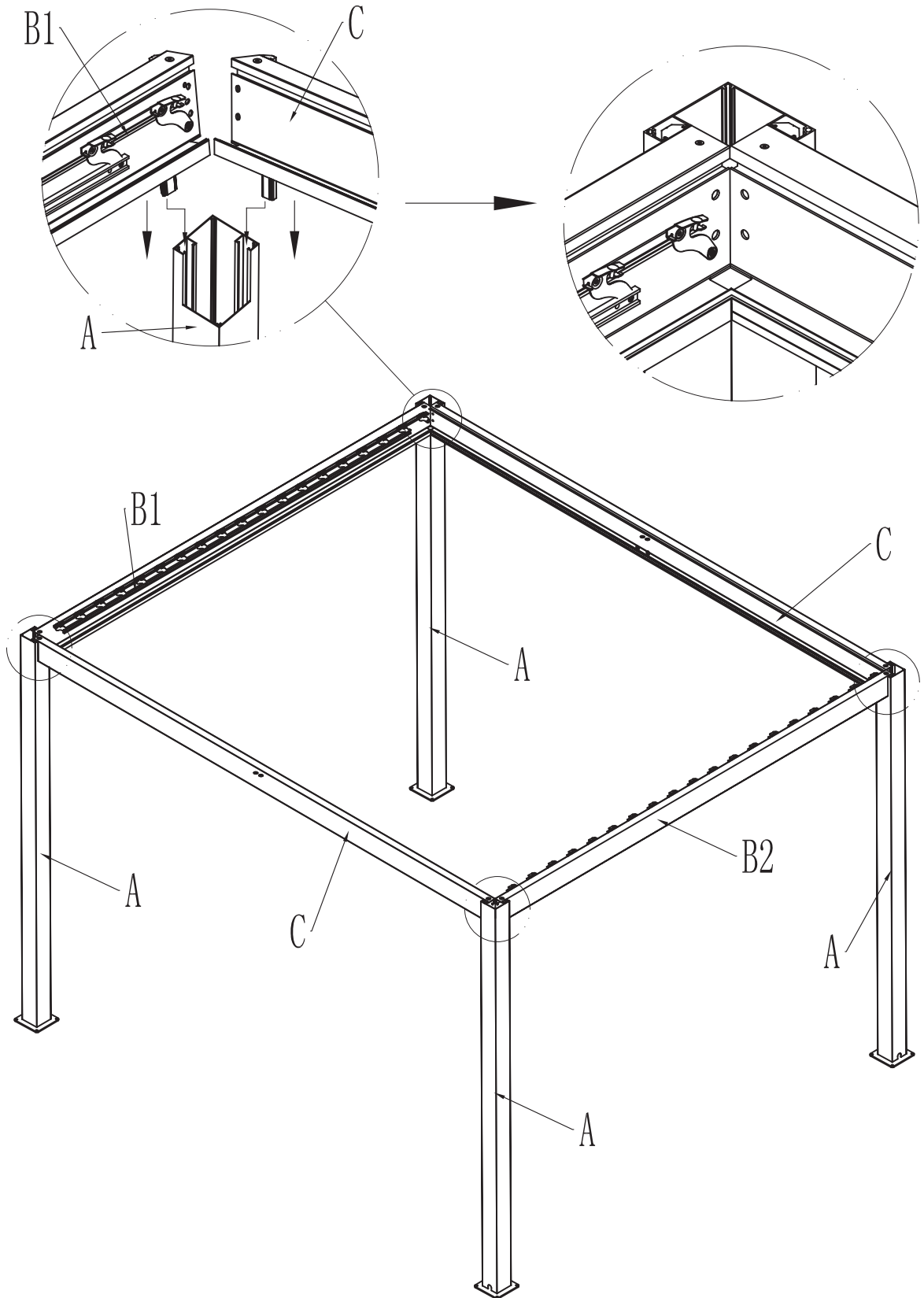

4. Insert the corner nut strips on the B1/B2/C components of the crossbeam into the slots of column A as shown in the diagram.



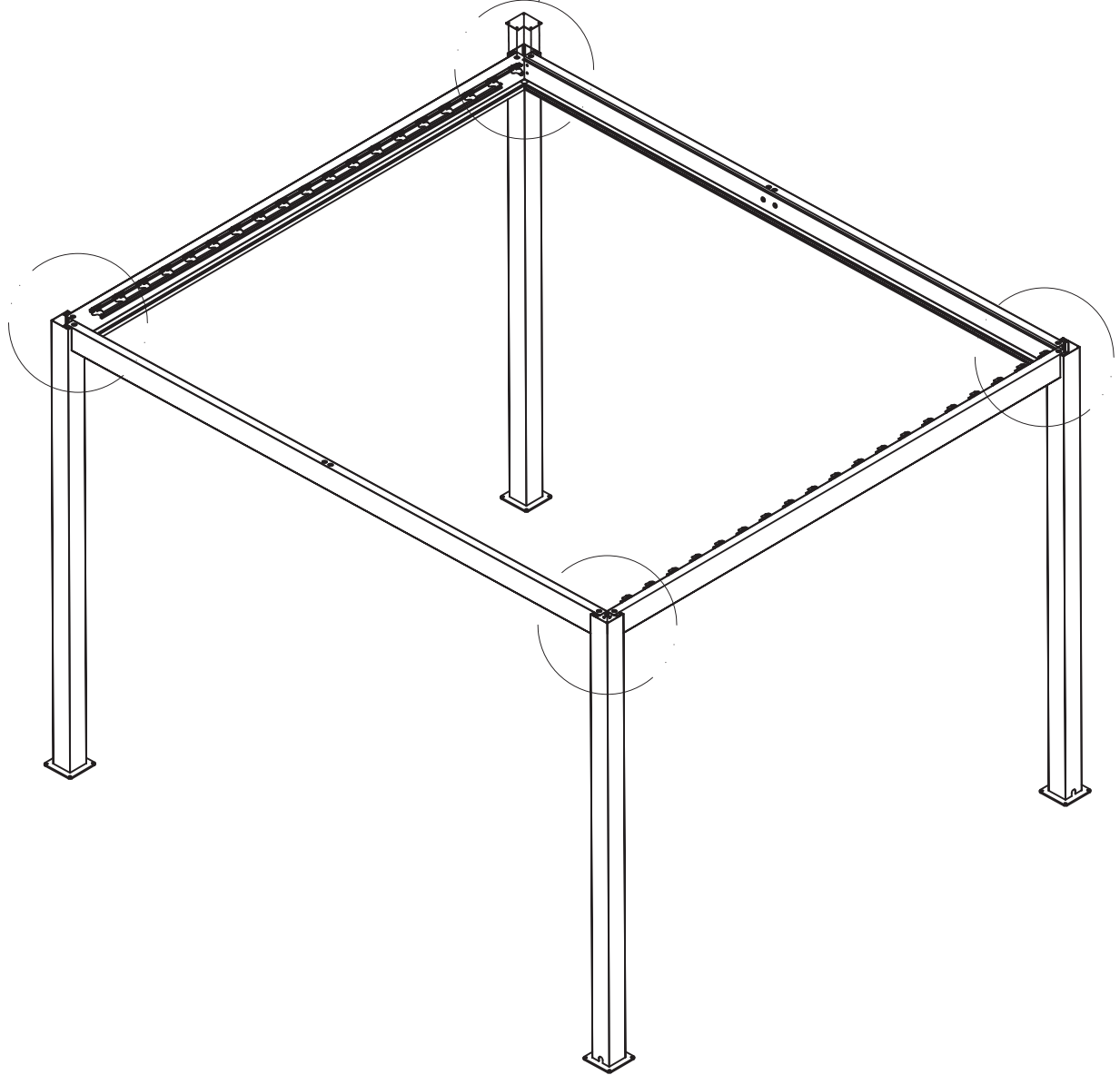
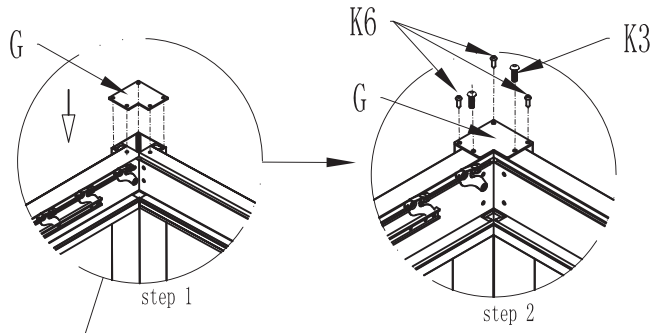

6. Install the four column cover plates G on the connecting angles between the column and the crossbeam, and then install the screws K3/K6 in sequence; Tighten K3/K6, then tighten the K2 screw from step 4.

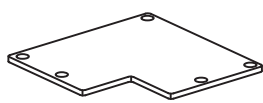

<p>K6</p>  <p>QTY: 12PCS</p>	<p>G</p>  <p>QTY: 4PCS</p>
<p>K3</p>  <p>QTY: 8PCS</p>	<p>Page 6</p>

7. Adjust the position of the four columns, so that they remain perpendicular to the ground. Simultaneously measure the top width between each two columns to be consistent with the width at the bottom of the ground. Then use a marker to mark the corresponding positions of 16 bottom plate and ground connection holes on the ground through the holes on the bottom plate.

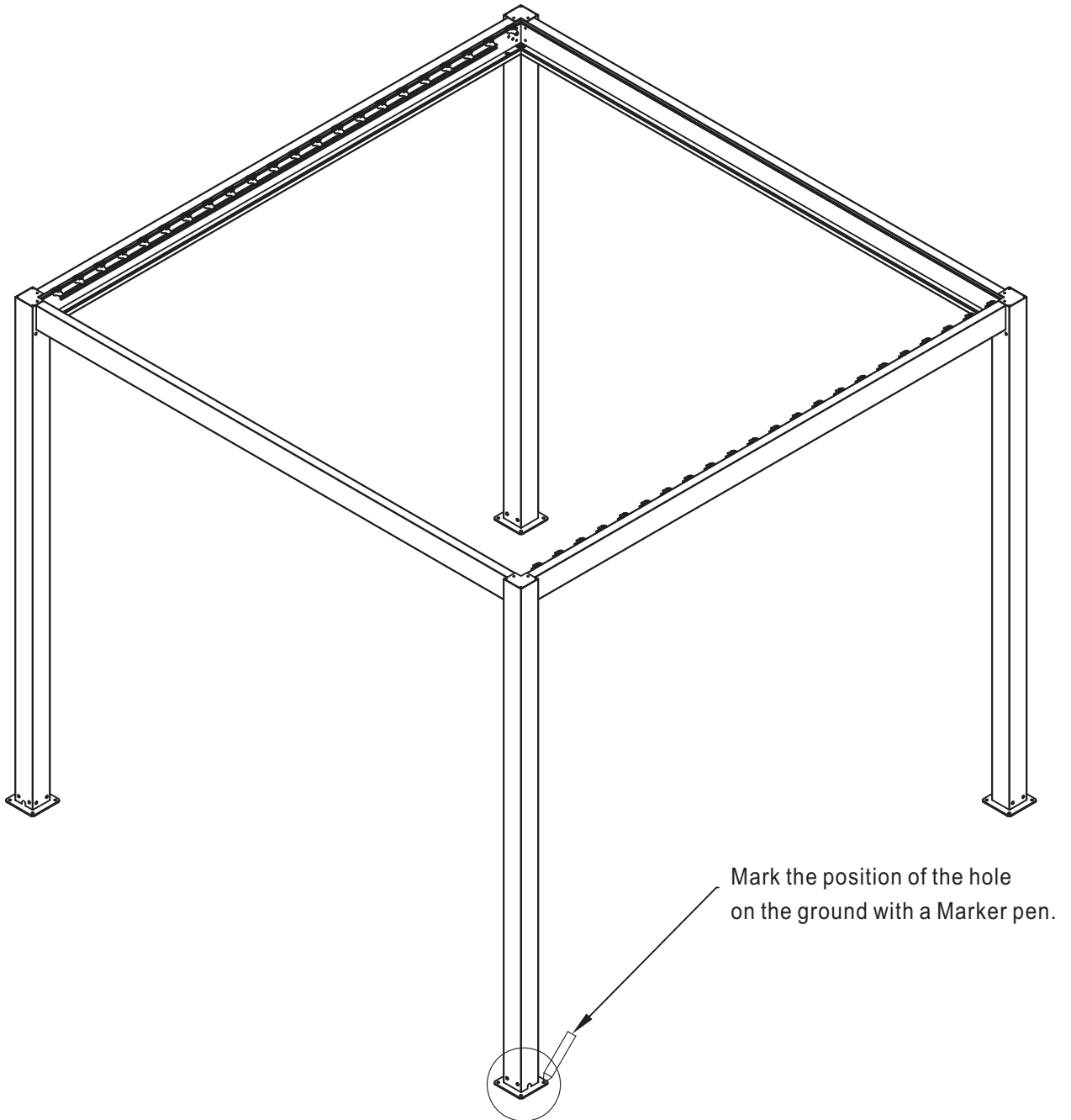

Tool used: marker pen (to be provided by the installation worker)



Mark the position of the hole on the ground with a Marker pen.

8.Remove the product from the mark  
and use an impact drill to drill  $\Phi 10 \times 80$  holes  
at each of the 16 marked positions on the ground.

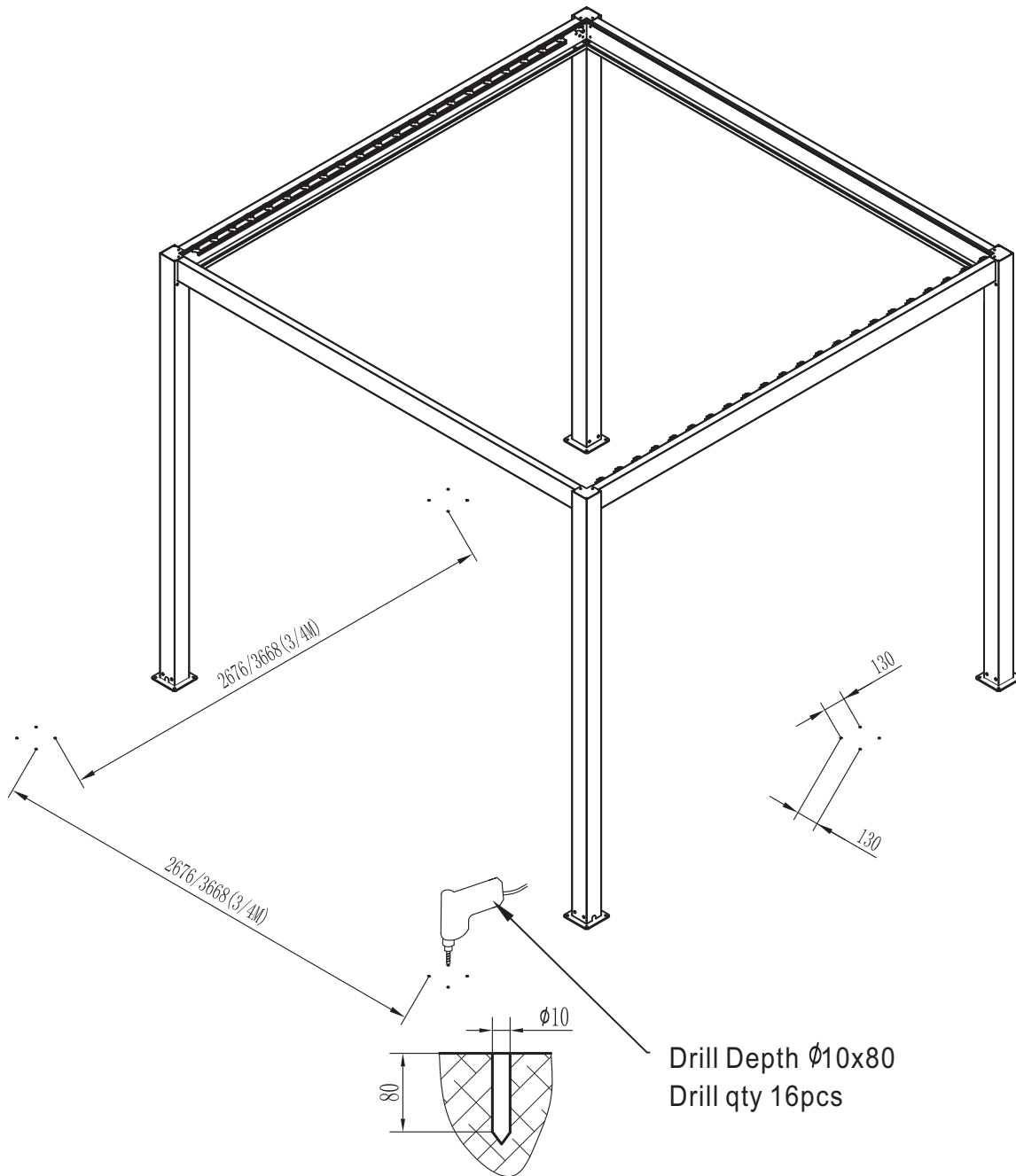

Tool Used: Impact Drill (to be provided  
by the installation worker)

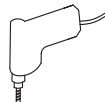

Tool Used: Impact bit  $\Phi 10$  (to be provided  
by the installation worker)

9. The plastic expansion pipe is put into the bottom hole of the column, then the product is moved back to the drilling hole, and the bottom plate holes of the four columns are respectively aligned with the drilling holes on the ground, then the gasket is put into the woodworking screw, and is respectively fixed with the ground, cover the nut cover P.

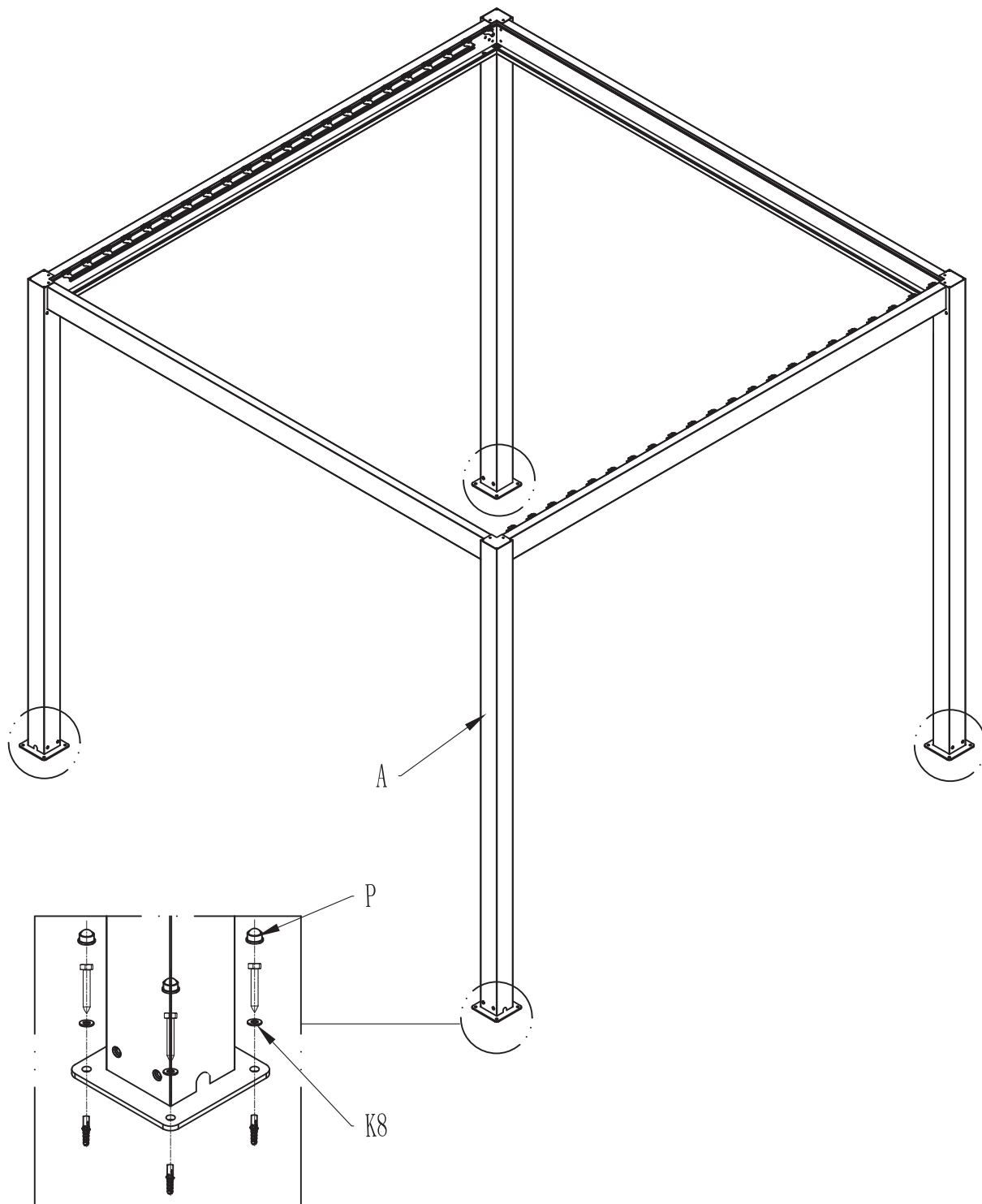

K8

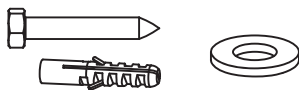

QTY:16PCS

P



QTY:16PCS

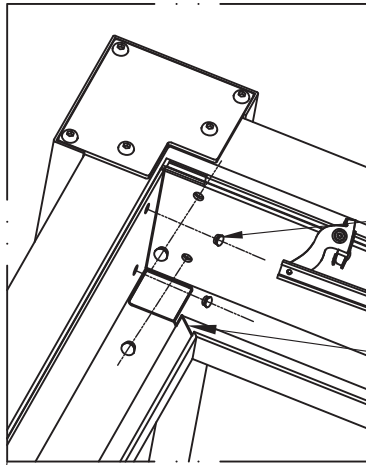

10. In the crossbeam hole plug hole plug 0, the column four corners of the nozzle around and the crossbeam on the joint evenly coated with glass glue k9.

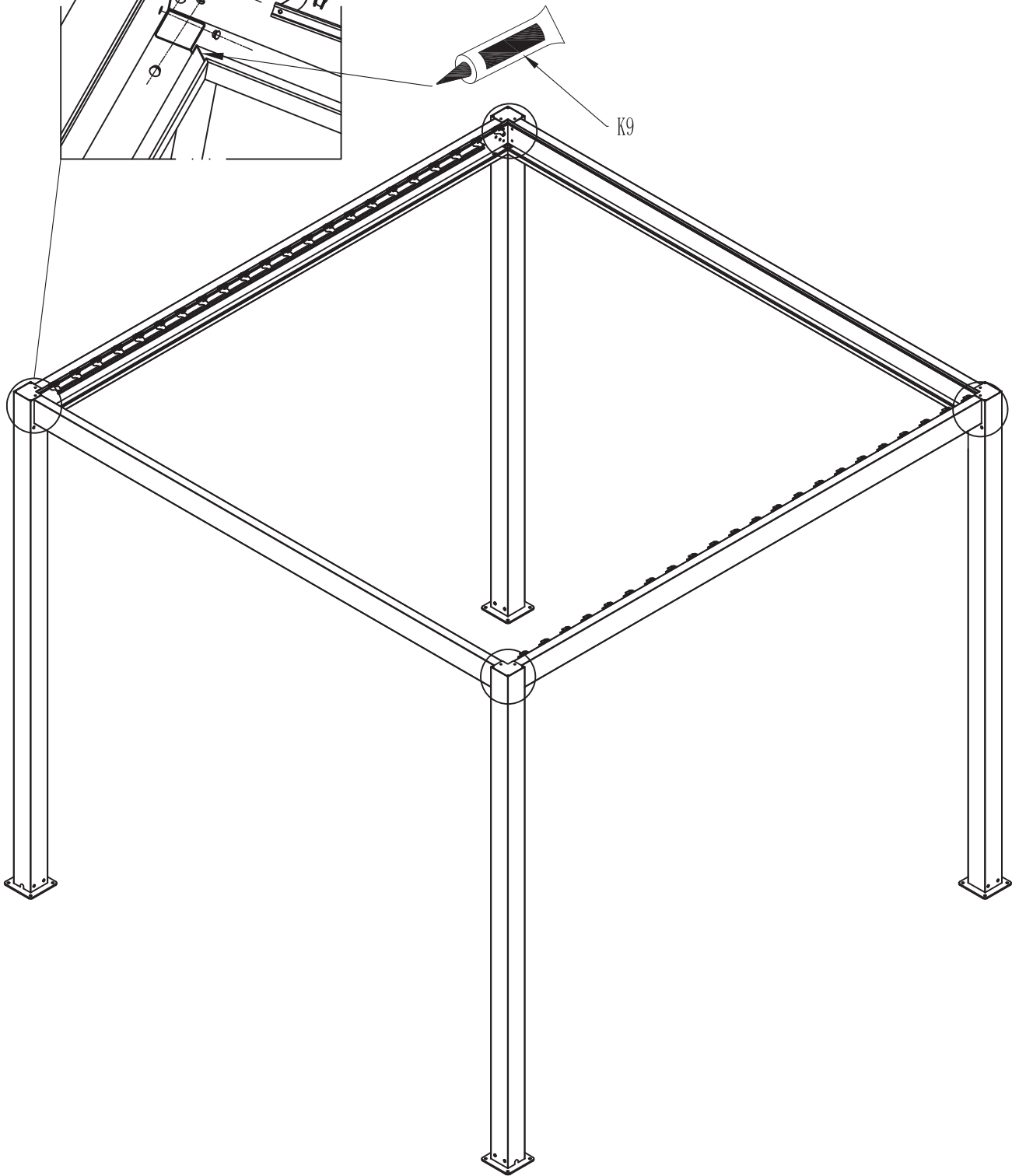

K9

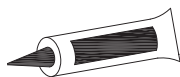

QTY: 1PC

0



QTY: 16PCS

11. Put the middle crossbeam D on the front and back crossbeam C, put the spacer K 4 on the screw k 3, connect the middle crossbeam D to the front and back crossbeam C, pay attention not to tighten the screw.

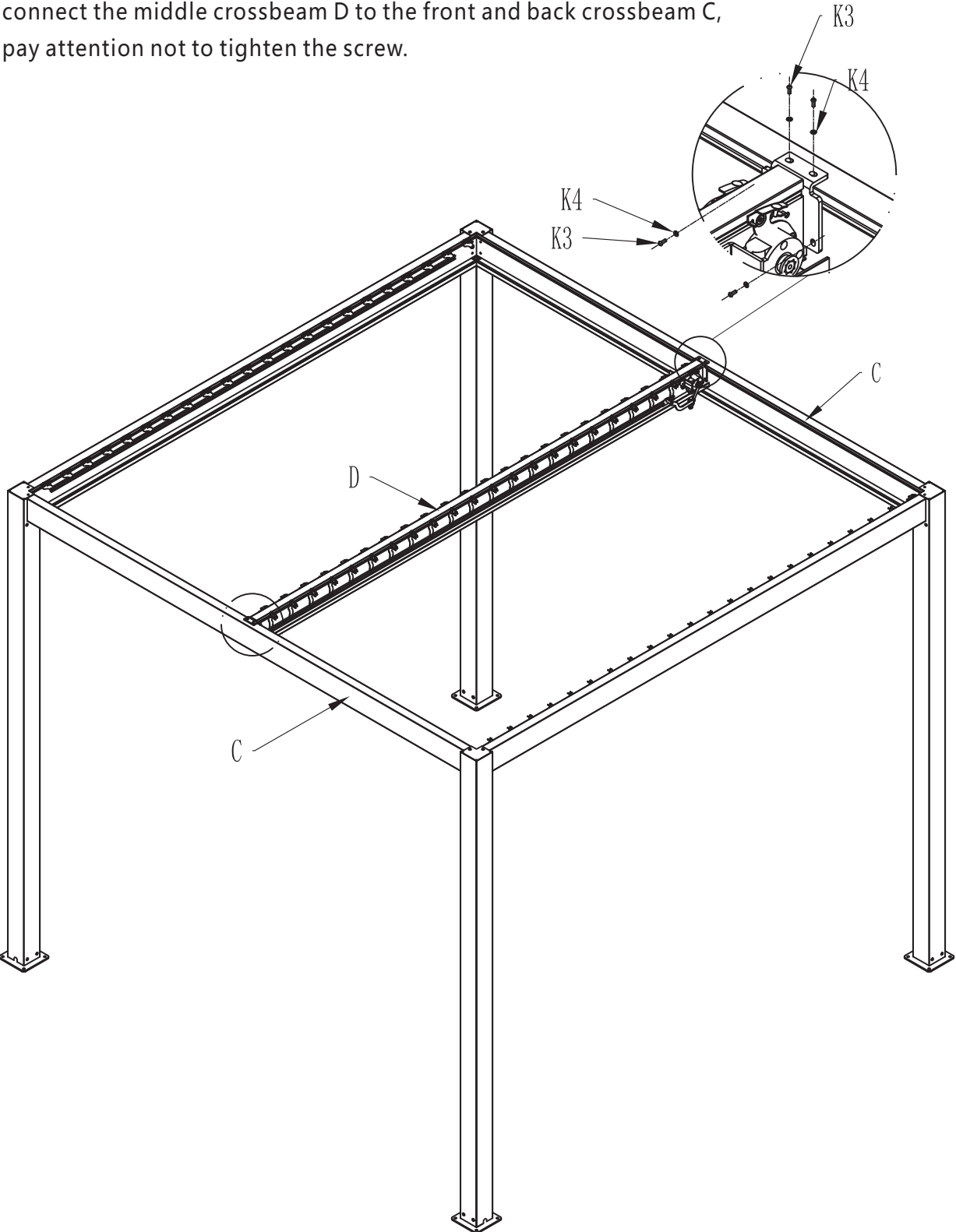

K3

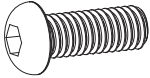

QTY: 8PCS

K4



QTY: 8PCS

12. According to the diagram, first clip the flap E into the supporting tail of the two end beams, then press down on the flap so that the card is clamped and installed in the direction indicated by the arrows at the 1 and 2 positions of the clamp respectively, and fasten the corresponding position of the flap according to the diagram.

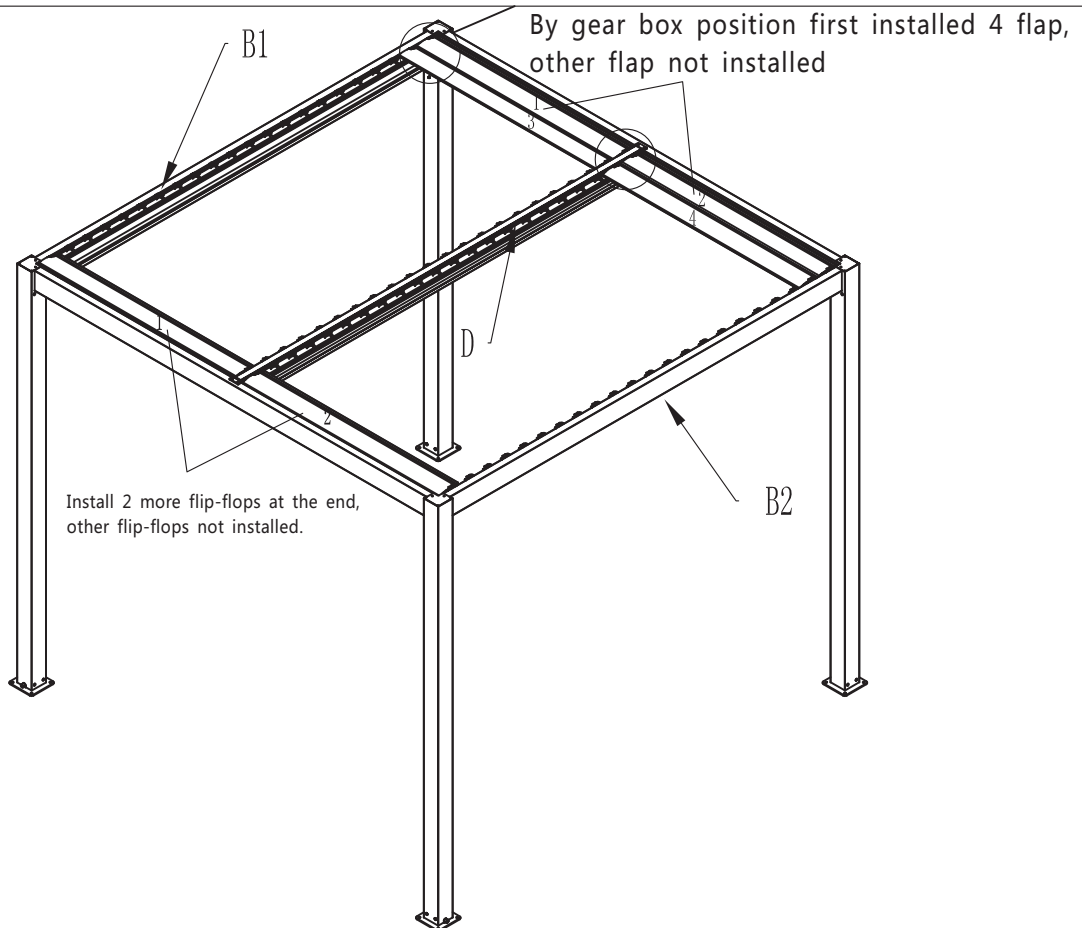
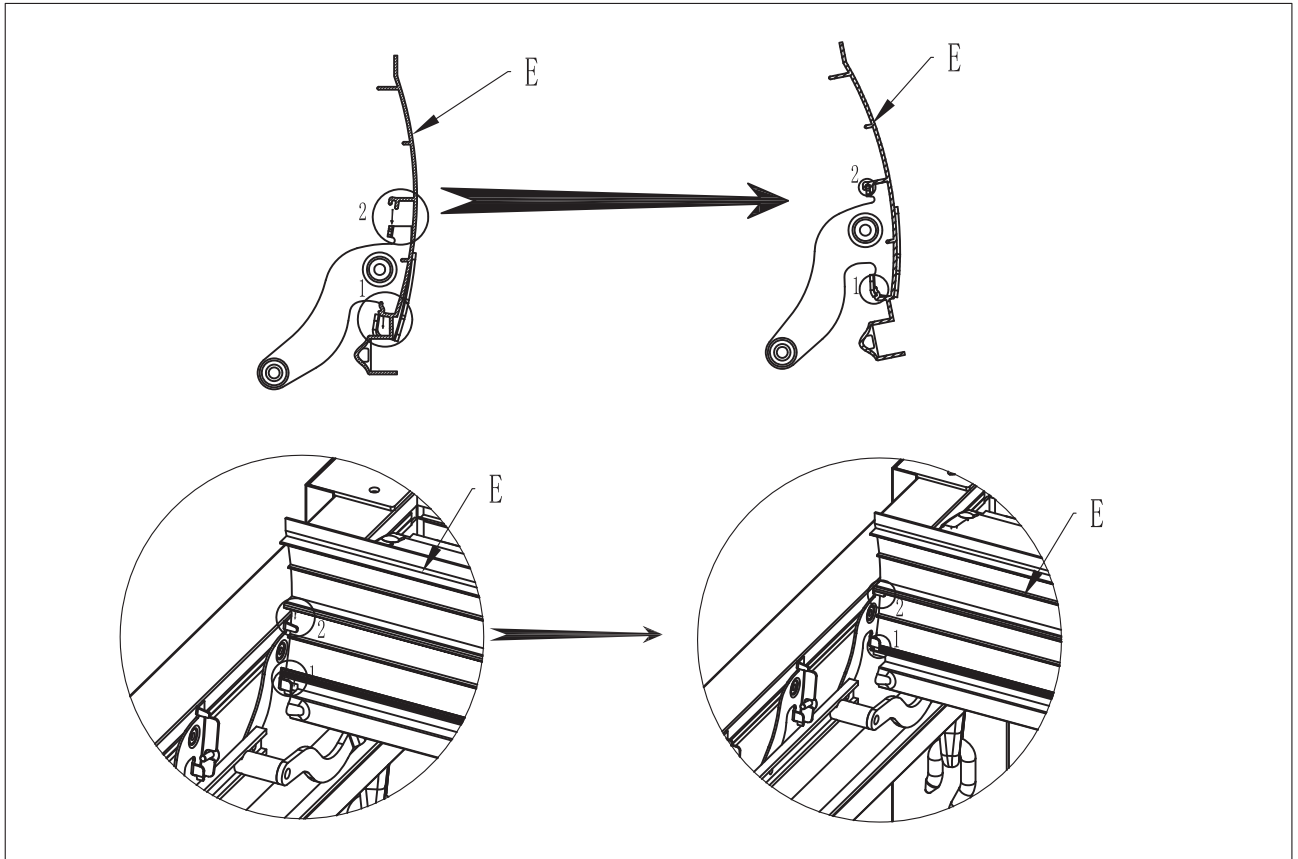

13. Tighten and fix the screw k 3 in step 11, and then fasten the remaining flap in turn.

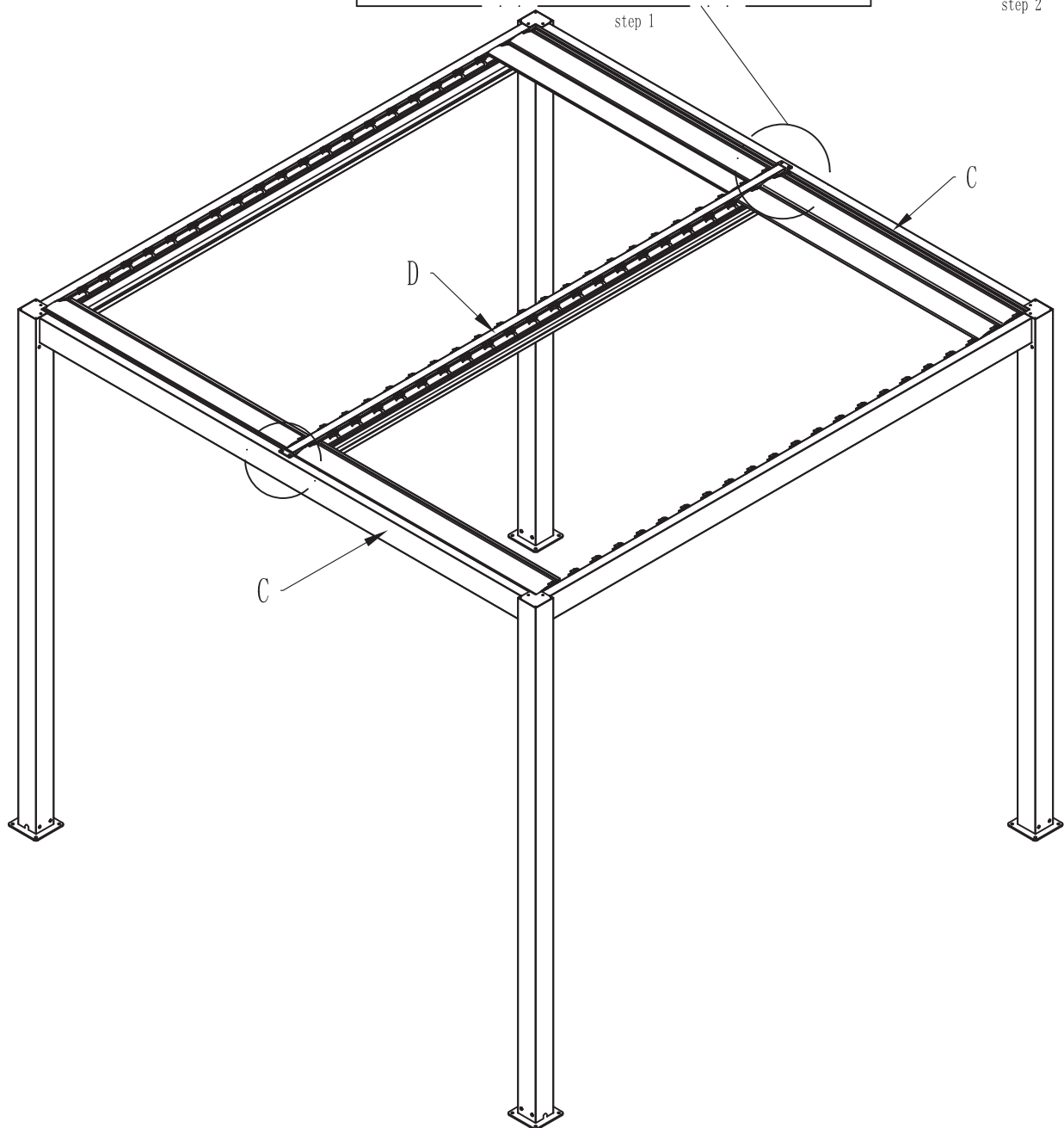
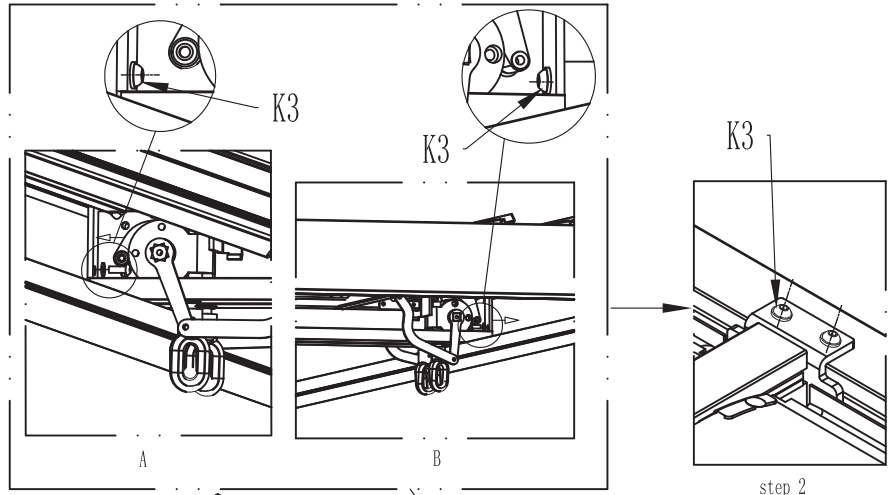



## 14. Each flap is fitted with a plastic plug at both ends

Step 1. If the holes are not aligned as shown, they need to be adjusted

Step 2. As shown, insert the screwdriver into 1 place and pry the flap support piece according to the direction 2, so that the hole of the flap support piece is aligned with the center of the hole of the flap piece

Step 3. After adjustment, the hole of the flap support member is aligned with the center of the hole of the flap

Step 4. Install the plastic plug N on the front mounting flap as shown in the picture box below

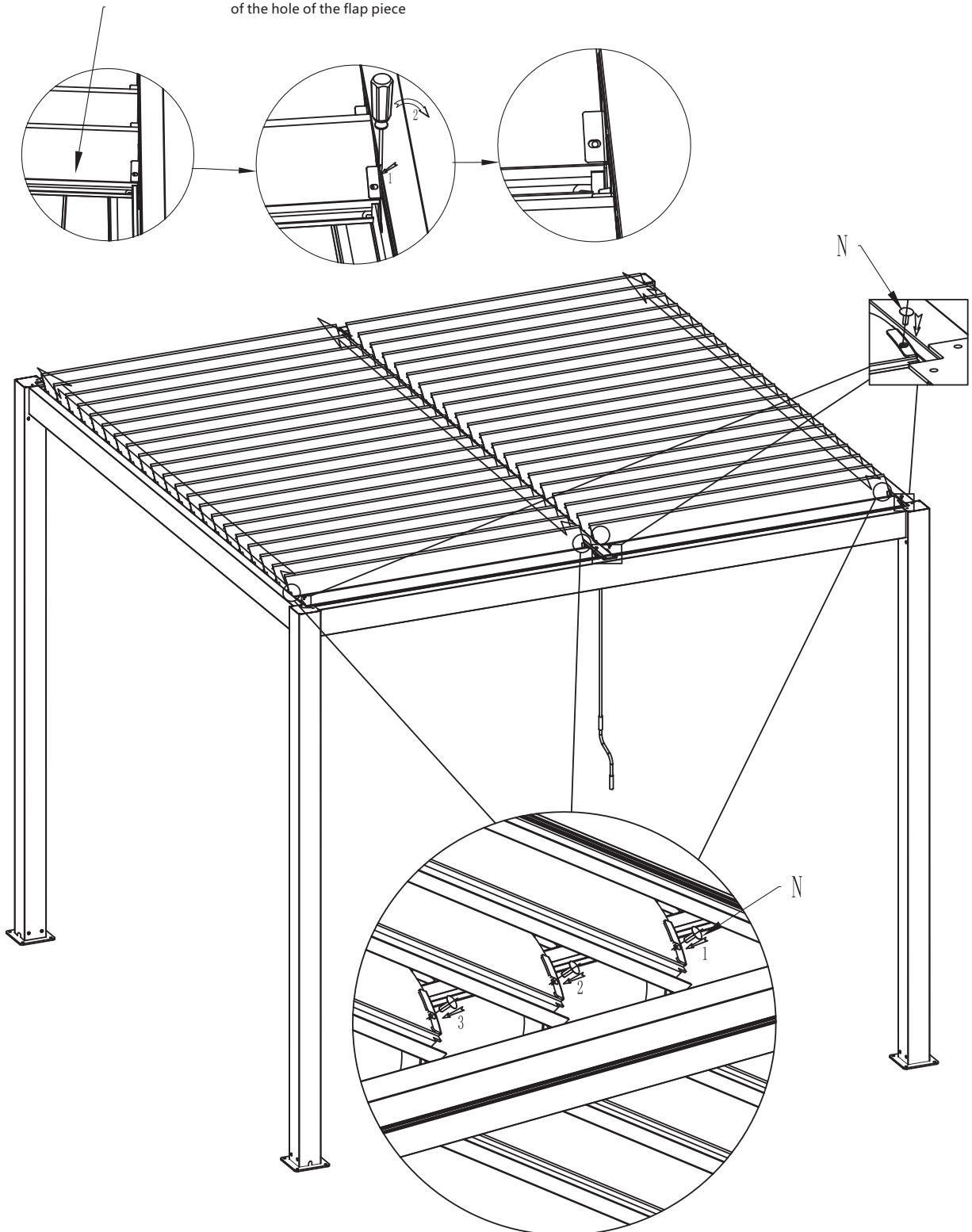

Step 5. Open the flap in half and insert the plastic plug n into the plug mounting holes at both ends of the flap as shown in the drawing in the upper circle.

15. Hang the hand Cranck M and turn it so that the flap opens or closes to complete the installation.

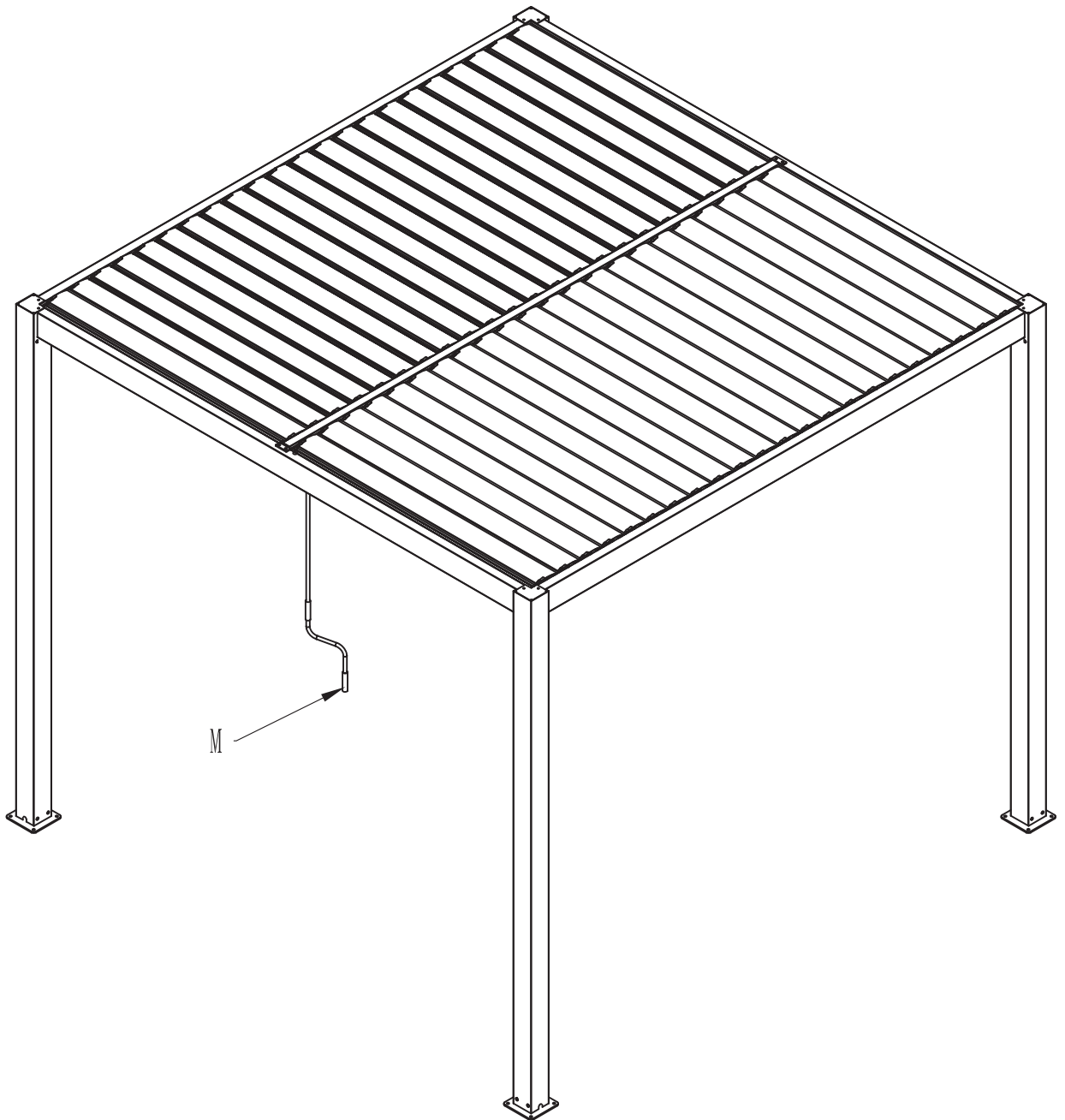

**Produktinformation /Montageanleitung/Bedienungsanleitung für Gartenmöbel**  
**Product information/Assembly manual/Use manual for Outdoor Furniture**

Art. Nr. 250.003646 , 250.003647 , 250.003862 (Aluminium)

1.

**DE) WICHTIG: AUFMERKSAM LESEN & FÜR SPÄTER GUT AUFHEBEN.**

**DIESES PRODUKT IST NUR FÜR DEN PRIVATEN GEBRAUCH IM HAUSHALT BESTIMMT, NICHT FÜR GEWERBLICHE, INDUSTRIELLE bzw. OFFENTLICHE NUTZUNG VORGESEHEN**

**EN) IMPORTANT: READ CAREFULLY & KEEP ACCURATELY FOR FUTURE.**

**THIS PRODUCT IS INTENDED ONLY FOR USE IN A PRIVATE HOUSHOLD, NOT SUITABLE FOR ANY PUBLIC, COMMERCIAL OR INDUSTRIAL USE!**

**2. Montage/Installation.**

**DE) Wichtige Hinweise für korrekte Möbelsmontage:**

*Manche Möbelstücke sind fertig zusammengebaut und benötigen deshalb keiner Montage mehr.*

*Sie müssen die Schrauben nur bei Möbeln mit Metallverbindungen überprüfen und gegebenenfalls anziehen.*

*Bestimmte Möbelstücke werden in zerlegtem Zustand geliefert. In diesem Fall müssen Sie wie folgt vorgehen:*

*-Nehmen Sie das zerlegte/teilweise zerlegte Produkt aus der Verpackung.*

*-Nehmen Sie den Montageplan in die Hand und vergewissern Sie sich, dass kein Bauteil fehlt.*

*-Bauen Sie das Möbelstück nach dem Montageplan zusammen.*

*- Ziehen Sie die Schrauben während der Montage nie ganz an. Dies erschwert den weiteren Verlauf des Zusammenbaus.*

*Warten Sie damit bis das Möbelstück komplett zusammengebaut ist.*

*- Für Möbel aus Aluminium, zu starkes Festdrehen der Befestigungsschrauben führt zur Zerstörung des Schraubengewindes oder zur Beschädigung des Möbels. Keinen Akkuschauber nutzen.*

**EN) Important notes for proper furniture assembly:**

*Some pieces of furniture are completely assembled and therefore do not require any assembly. You only have to check the screws on furniture with metal connections and tighten if necessary.*

*Certain pieces of furniture are delivered in disassembled condition. In this case, proceed as follows:*

*-Remove the disassembled/or partially assembled product from its packaging.*

*- Check carefully the assembly plan and make sure that no component is missing.*

*- Assemble the piece of furniture according to the assembly plan.*

*- Do not fully tighten the screws during assembly. This makes the further steps of the assembly more difficult. Wait with tightening until the piece of furniture is completely assembled.*

*- In case of furniture made of aluminium, excessive tightening of the fastening screws leads to the destruction of the screw thread or to the damage of the furniture. Do not use an electric screwdriver.*

**3. DE Wartung- & Pflegehinweise:**

**Diese Gartenmöbel sind wartungsfrei. Jedoch, wenn Sie die Möbel sauber halten und sie richtig lagern, können Sie sie Jahr für Jahr genießen.**

**Zur Beibehaltung der Stabilität des Möbelstücks sollten alle Schrauben mind. einmal pro Saison nachgezogen werden.**

**Reinigung:** mit milder Seifenlösung reinigen. Kunststoff- Holz- oder Metallmöbel nicht mit starken Reinigungsmitteln oder scheuernden Materialien behandeln - das könnte zu Beschädigung oder Verfärbung der Möbel führen.

**Lagerung:** Gartenmöbel möglichst in Wintersaison an einem trockenen, kühlen Ort lagern. Werden die Möbel draußen gelagert, sollte man sie schräg stellen und mit einer wasserabweisenden Hülle abdecken. Wichtig ist, dass die Luft zirkulieren kann, um Feuchtigkeitsstau zu verhindern.

**Reparieren:** Pulverbeschichtung schützt die metallischen Teile vor Rost. Falls Farbe abblättern sollte, ist das Material nicht mehr gegen Rost geschützt. Zum Reparieren des Schadens und Wiederherstellen der Schutzfunktion die Stelle trocknen lassen und mit Lackfarbe für Metall überstreichen.

Das Holzmöbel ist mit mehreren Schichten Farbe/Lack behandelt. So lange die Farbe/der Lack ansehnlich ist, reicht es, das Möbelstück sauber zu halten. Wenn der Lack abblättert oder ausgelaugt wirkt, kann das Möbel neu gestrichen bzw. die Farbe ausgebessert werden.

**Neu lackieren:** Zum Reinigen, Lackieren und Trocknen einen schattigen Platz wählen. Direkte Sonnenbestrahlung vermeiden. Farbe für Außenbereich verwenden.

**1. Wenn nötig, das Möbelstück mit einem feuchten Tuch und milder Seifenlösung säubern. Mit einem weichen, sauberen Tuch trocken nachwischen.**

**2. Wenn die Oberfläche trocken ist, abgeblätternen Lack abschaben und bei Bedarf die Oberfläche überspachteln.**

**3. Damit die Farbe gut haftet, die gesamte Oberfläche durch Anschleifen mit feinem Sandpapier für den Anstrich vorbereiten.**

**4. Das Möbelstück in der gewünschten Farbe lackieren. Dabei die Anleitungen des Farbherstellers bezüglich Trockenzeit usw. genau befolgen.**

#### **EN Maintenance & Care Instructions:**

**This outdoor furniture requires no maintenance. However if you keep the furniture clean and store it properly you can enjoy it year after year.**

**To increase the stability of your furniture, re-tighten the screws at least once per season.**

**Clean:** Wipe clean with a mild soapy solution. It is not recommended to clean plastic, wooden or metal furniture with a strong cleaner or an abrasive material because it may discolour or damage the surface.

**Storing:** If possible, store your outdoor furniture during the winter season in a dry and cool place indoors. When stored outside, tilt the furniture and preferably use waterproof covers. Make sure air can circulate to avoid moisture. In freezing temperatures, plastic can weaken and is not recommended for use.

**Repair:** The metallic parts of the garden furniture are protected from rust with a powder coating of plastic paint. If for some reason the coating comes off, the metal is not protected and rust may occur. To repair the damage, wipe clean and repaint to restore protection

The wooden furniture is painted with several coats of paint/lack and as long as the paint/lack is fresh, it is sufficient to clean the furniture regularly. If the paint should begin to flake or look worn you can repaint the furniture or touch it up where needed.

**How to repaint:** Choose a place in the shade for cleaning, repainting and letting the furniture dry. Avoid direct sunlight. Use paint for outdoor use.

**1. Wipe clean with a soft cloth dampened in water and a mild soapy solution, if necessary. Wipe dry with a clean and dry cloth.**

**2. When the surface is dry, scrape away any paint flakes. Use putty to fill spots, if necessary.**

**3. Sand the entire furniture lightly with sandpaper to get a good surface for the paint to adhere to.**

***4. Paint the furniture in the colour of your choice and be sure to follow the paint manufacturer's instructions for drying times, etc.***

**Hersteller/Importeur:  
Producer/Importer:  
Home Product Import GmbH  
Graf-Zeppelin-Str.5,  
46045 Oberhausen, [www.h-p-i.de](http://www.h-p-i.de)  
Chargen-Nr: KT30184 / DKT30285 /  
DKT30708 / DKT30682**