

W 4.2W
 LED Board
 lm 400lm
 t 15000h
 T_x 3000K
 7500
 <1s

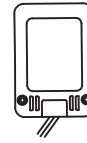

993891



230V / 50Hz

2x LED Board /4.2W

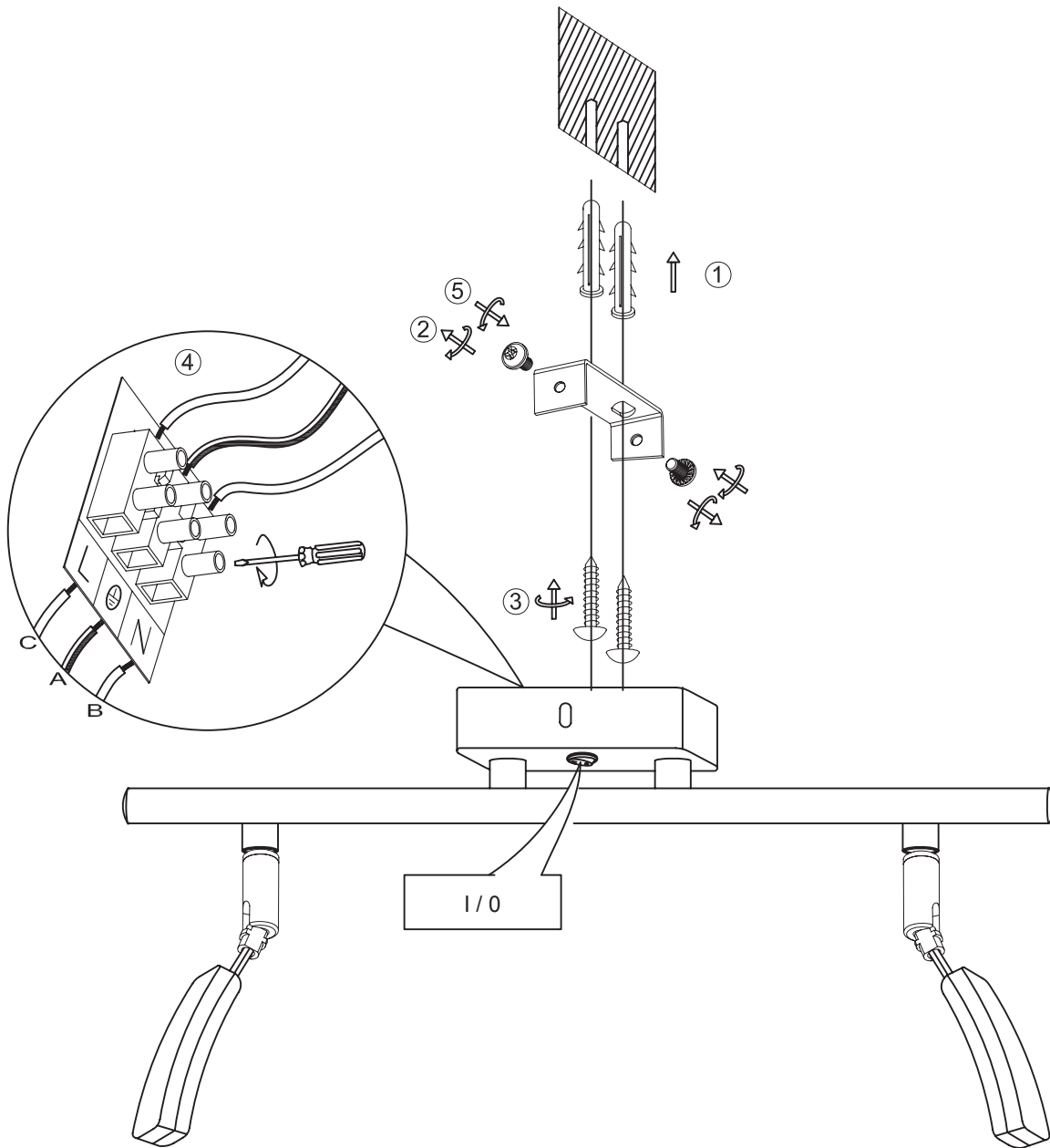

Bitte geben Sie bei technischen Fragen die Chargennummer (xxxxx-xx-xx-xxxxx-xxxxx) an. Diese finden Sie auf dem Typenschild.
 Please let us know the batch number (xxxxx-xx-xx-xxxxx-xxxxx) for any technical questions. This can be found on the rating label.
 Lors de demande d'assistance technique, veuillez indiquer le numero du lot (xxxxx-xx-xx-xxxxx-xxxxx). Celui-ci se trouve sur la plaque d'identification.

08/2016